

第60回 技能五輪全国大会 建築大工職種 競技課題図

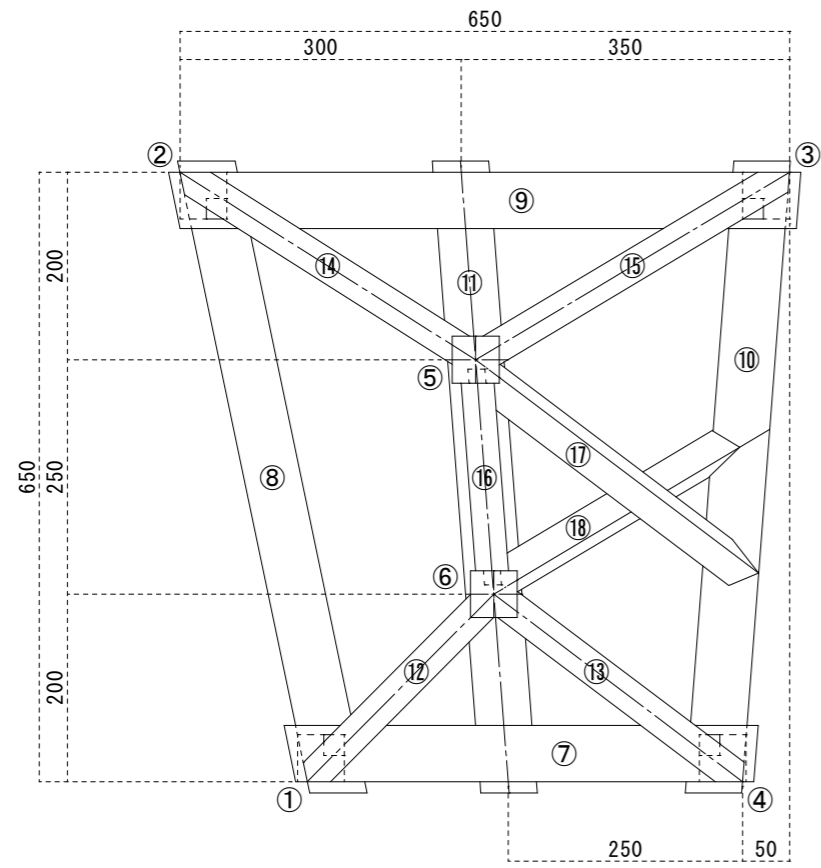

平面図

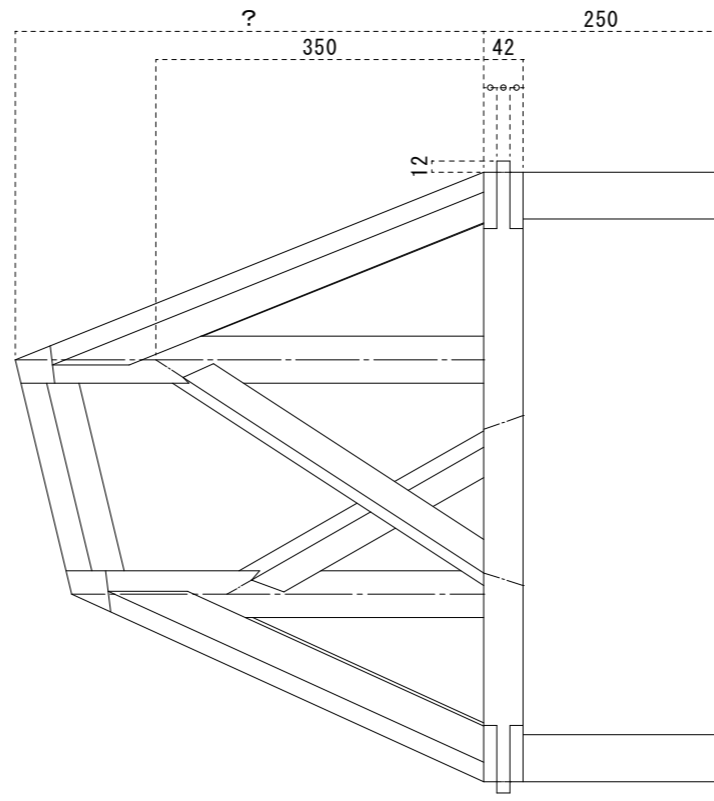

側面図

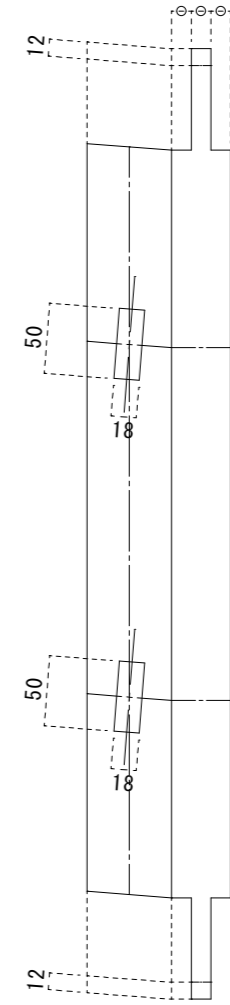

⑪ 梁・柱取合い詳細図

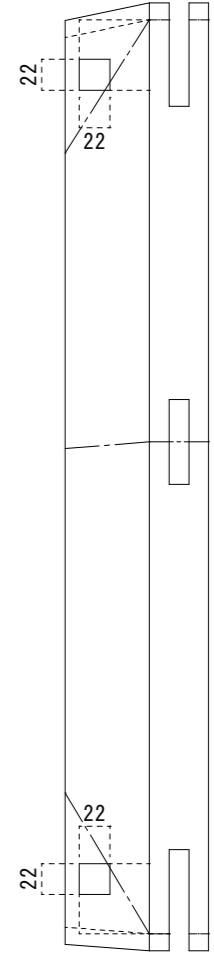

⑨ 桁・柱取合い詳細図

- ※ 単位はmm
- ※ 平面基本図○印は各取合い位置を示す
- ※ 平面⑬部材と⑰部材は平行
- ※ 平面⑮部材と⑱部材は平行

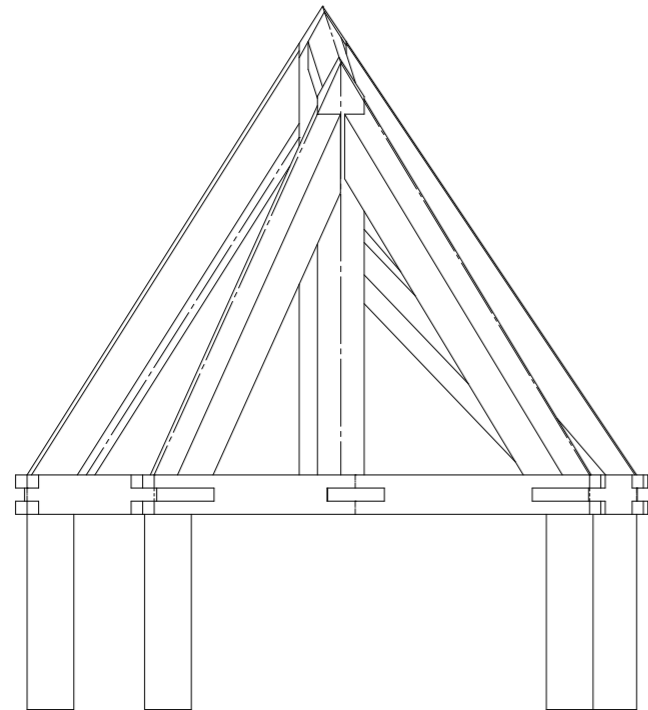

正面図

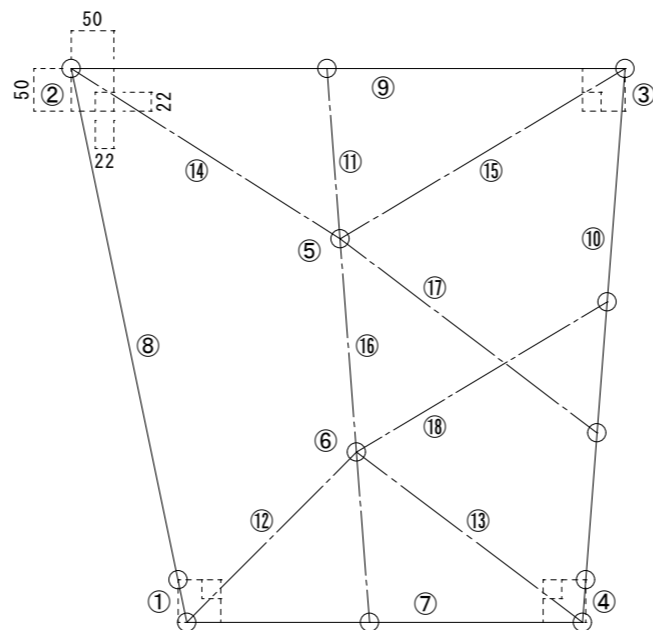

平面基本図

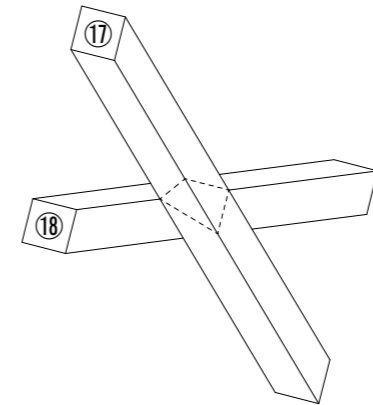
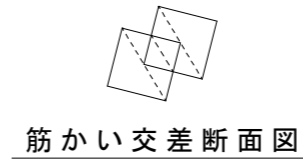

筋かい詳細図

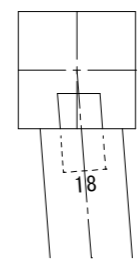

棟木ほぞ詳細

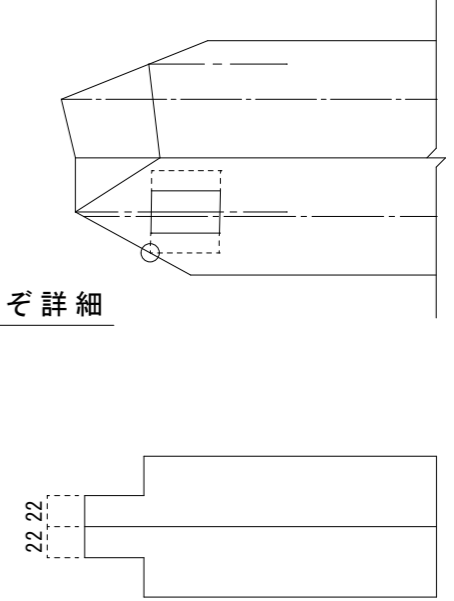

⑤ 柱・棟木取合い詳細図

①②③④ 柱ほぞ詳細図