

第51回 技能五輪全国大会「建築大工」職種 競技課題「変形五角形小屋組」

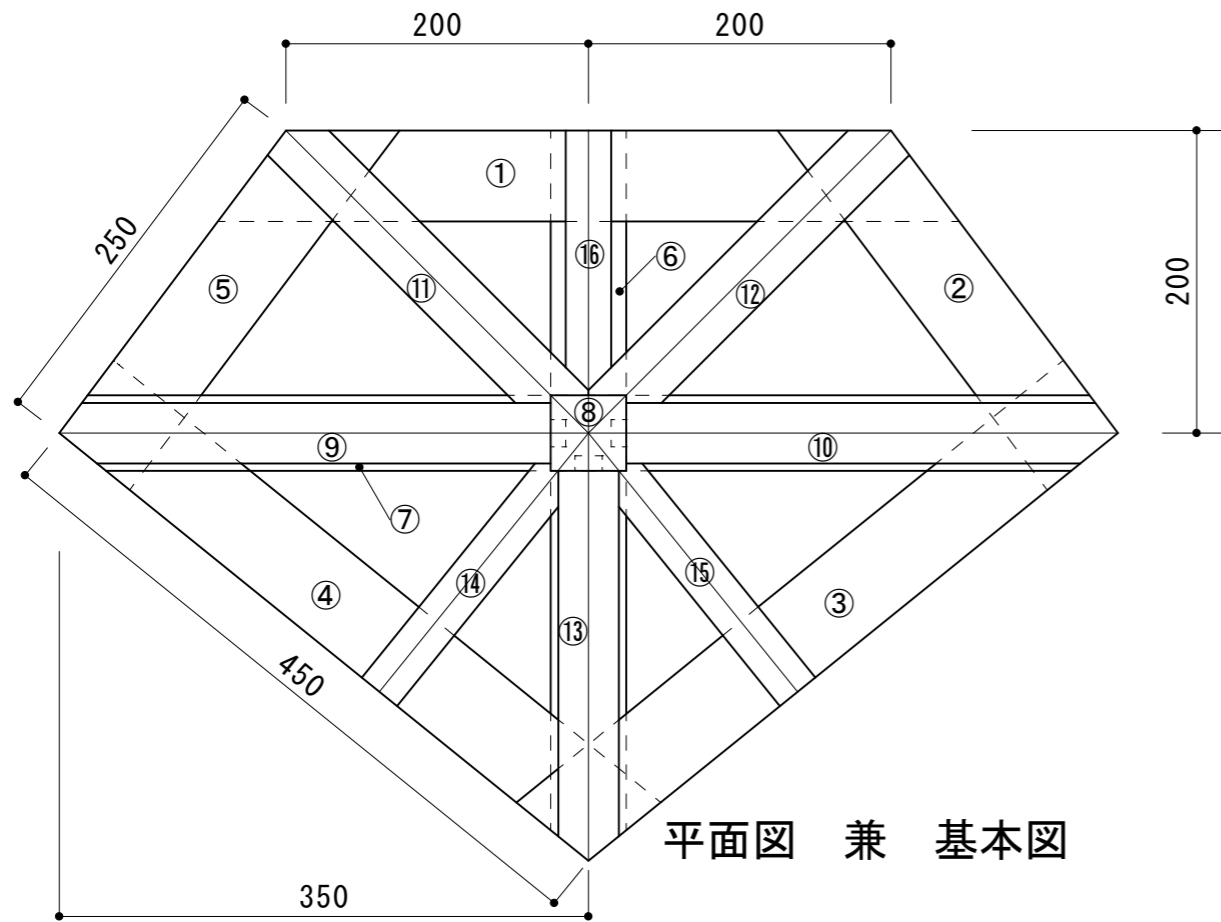

平面図 兼 基本図

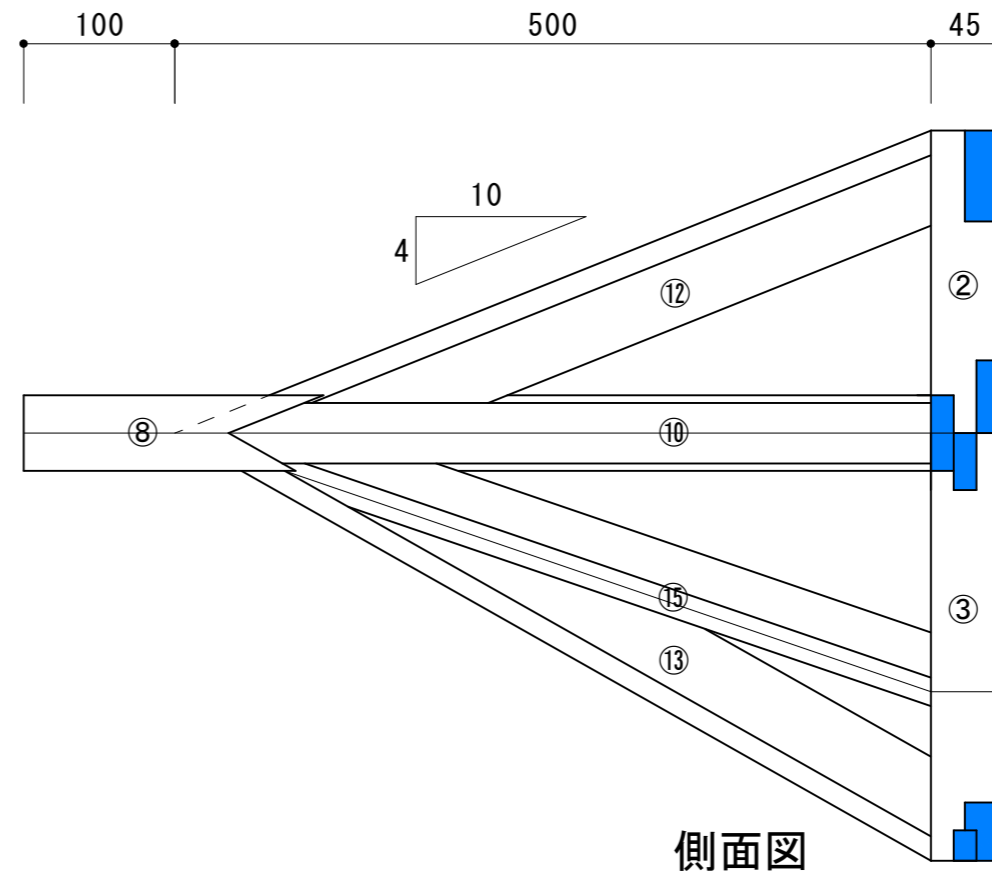

側面図

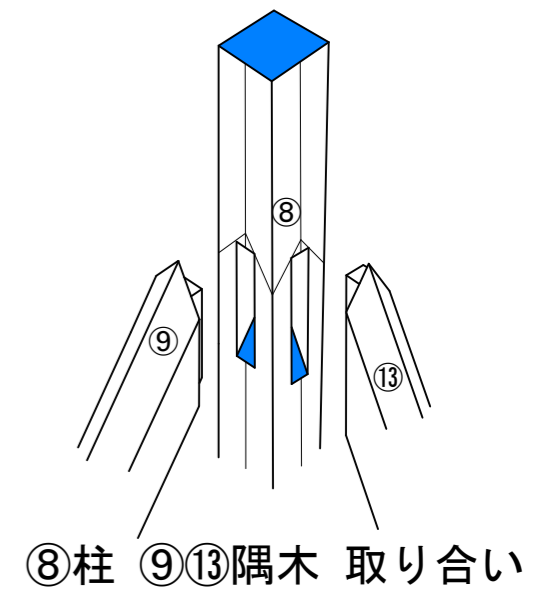

⑧柱 ⑨⑬隅木 取り合い

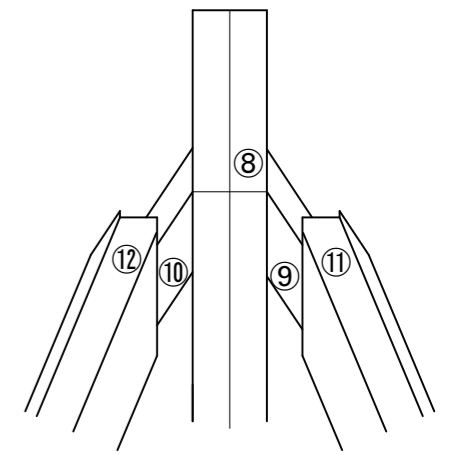

⑧柱 ⑪⑫隅木 取り合い

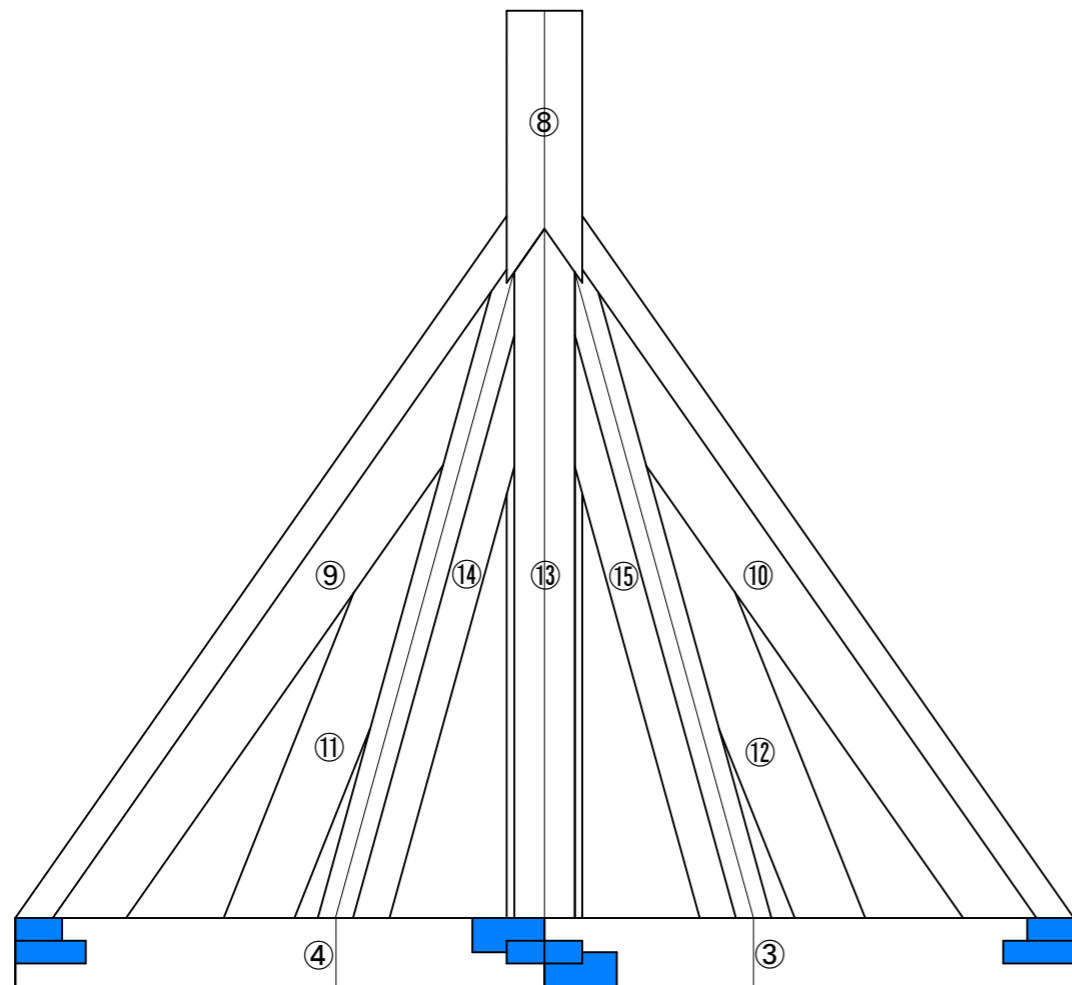

正面図

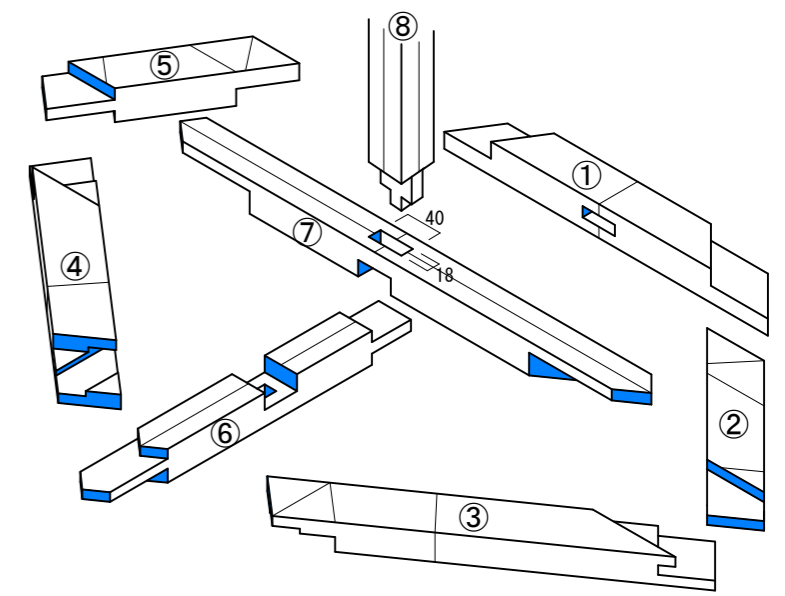
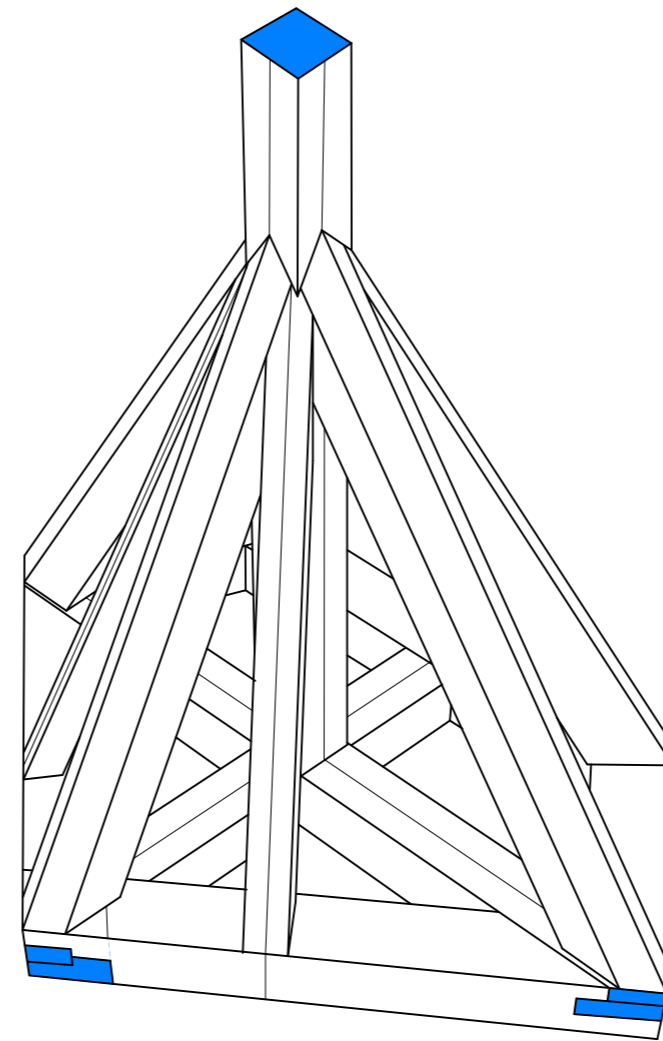

①②③④⑤桁 ⑥⑦梁 ⑧柱 取り合い

現寸図配置参考図

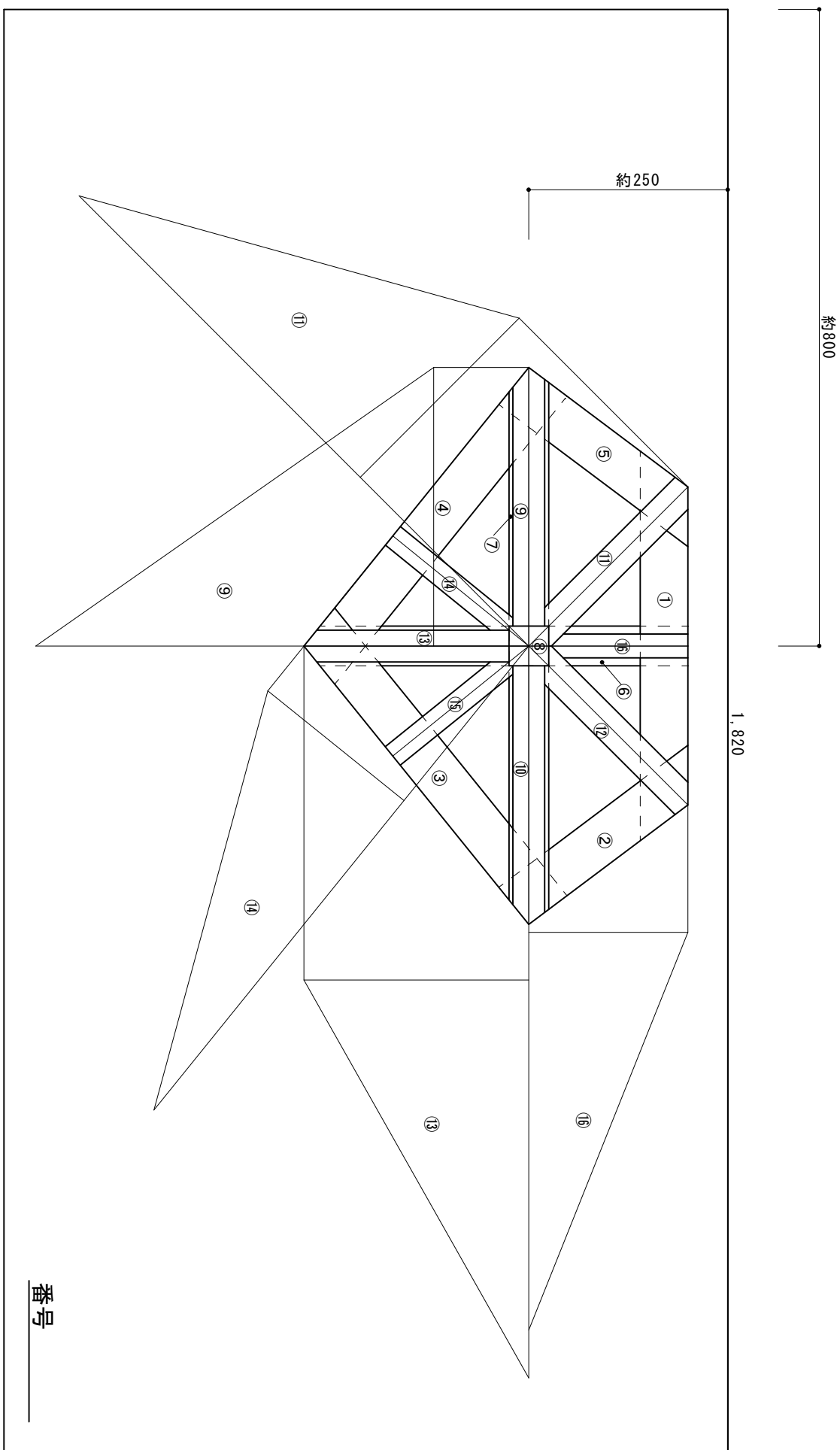

番号