

Technical Description

# Robot Systems Integration

Skill 63



WorldSkills International, by a resolution of the Competitions Committee and in accordance with the Constitution, the Standing Orders, and the Competition Rules, has adopted the following minimum requirements for this skill for the WorldSkills Competition.

The Technical Description consists of the following:

<b>1 Introduction</b> .....	<b>3</b>
<b>2 The WorldSkills Occupational Standards (WSOS)</b> .....	<b>5</b>
<b>3 The Assessment Strategy and Specification</b> .....	<b>13</b>
<b>4 Assessment Design and Practice</b> .....	<b>14</b>
<b>5 The Test Project</b> .....	<b>18</b>
<b>6 Skill management and communication</b> .....	<b>22</b>
<b>7 Skill-specific safety requirements</b> .....	<b>25</b>
<b>8 Materials and equipment</b> .....	<b>29</b>
<b>9 Skill-specific rules</b> .....	<b>37</b>
<b>10 Expert knowledge and experience</b> .....	<b>39</b>
<b>11 Visitor and media engagement</b> .....	<b>41</b>
<b>12 Sustainability</b> .....	<b>42</b>
<b>13 References for industry consultation</b> .....	<b>43</b>
<b>14 Appendix</b> .....	<b>44</b>

# 1 Introduction

## 1.1 Name and description of the skill competition

### 1.1.1 The name of the skill competition is

Robot Systems Integration

### 1.1.2 Description of the associated work role(s) or occupation(s)

Within the last decade the number of robots installed in the world has increased dramatically. According to IFR (International Federation of Robotics), annual installations in the world from 2018 to 2023 increased by 5% on average each year to reach 541,302 robots installed in 2023. This requires both the capacity to manufacture these robots, and the skilled human resources to install them.

To be useful, the robot needs to be integrated within an overall process that will benefit from its availability. According to the robot application: pick and place, load and unload, palletization, welding, and so on, the role of the robot integrator is to think about and decide: what is the most appropriate type of robot to use; how to organize the parts flow; how best to program the robot; how to make the robot cell safe, etc. These are considerations for the robot manufacturer, the system integrator, and sometimes the end user.

The robot system integrator must provide technical solutions to the robotization of all or part of a system by

- Incorporating a multi-articulating arm, together with the associated handling tools or special processes (such as handling, machining, painting, and welding), to increase competitiveness and
- Supporting the ergonomics, health and safety of the users and people around them.

Through additional devices the robot can acquire several “senses”, such as sight and touch, in order to perform complex and precise tasks.

The robot system integrator must be aware of technological developments in the manufacturing process, control systems, multi-articulated arm, and the evolution of regulations for robotization. Preliminary study, implementation, electrical connection for power and other automated systems, integration of peripheral equipment, and programming, as well as documentation, maintenance, and troubleshooting, are all essential tasks.

Across the globe, small and medium-sized enterprises (SMEs) outnumber large corporations. Collectively, they employ more people. SMEs represent the majority of businesses that have yet to realize the advantages of automation and robotics, as the big companies like the automobile industry have already done. SMEs can automate by investing in “custom” or “hard” automation, where the automation is designed and built for a specific purpose, or in flexible robot systems. Robot automation offers advantages of increased flexibility for meeting changing production requirements typically found in SMEs as well as lower investment through the use of standard industrial robots.

All in all, robot system integration represents a new, growing, and universal opportunity for skilled and committed technicians.

### 1.1.3 Number of Competitors per team

Robot Systems Integration is a team skill with two Competitors per team.

### 1.1.4 Age limit of Competitors

The Competitors must not be older than 25 years in the year of the Competition.

## 1.2 The relevance and significance of this document

This document contains information about the standards required to compete in this skill competition, and the assessment principles, methods, and procedures that govern the competition.

Every Expert and Competitor must know and understand this Technical Description.

In the event of any conflict within the different languages of the Technical Descriptions, the English version takes precedence.

## 1.3 Associated documents

Since this Technical Description contains only skill-specific information it must be used in association with the following:

- WSI – Code of Ethics and Conduct
- WSI – Competition Rules
- WSI – WorldSkills Occupational Standards framework
- WSI – WorldSkills Assessment Strategy
- WSI online resources as indicated in this document
- WorldSkills Health, Safety, and Environment Policy and Regulations
- WorldSkills Standards and Assessment Guide (skill-specific)

## 2 The WorldSkills Occupational Standards (WSOS)

### 2.1 General notes on the WSOS

The WSOS specifies the knowledge, understanding, skills, and capabilities that underpin international best practice in technical and vocational performance. These are both specific to an occupational role and also transversal. Together they should reflect a shared global understanding of what the associated work role(s) or occupation(s) represent for industry and business ([www.worldskills.org/WSOS](http://www.worldskills.org/WSOS)).

The skill competition is intended to reflect international best practice as described by the WSOS, to the extent that it can. The Standard is therefore a guide to the required training and preparation for the skill competition.

In the skill competition the assessment of knowledge and understanding will take place through the assessment of performance. There will only be separate tests of knowledge and understanding where there is an overwhelming reason for these.

The Standard is divided into distinct sections with headings and reference numbers added.

Each section is assigned a percentage of the total marks to indicate its relative importance within the Standards. This is often referred to as the “weighting”. The sum of all the percentage marks is 100. The weightings determine the distribution of marks within the Marking Scheme.

Through the Test Project, the Marking Scheme will assess only those skills and capabilities that are set out in the WorldSkills Occupational Standards. They will reflect the Standards as comprehensively as possible within the constraints of the skill competition.

The Marking Scheme will follow the allocation of marks within the Standards to the extent practically possible. A variation of up to five percent is allowed, if this does not distort the weightings assigned by the Standards.

### 2.2 WorldSkills Occupational Standards

Section		Relative importance (%)
1	<b>Work organization and management</b>	5
	The individual needs to know and understand: <ul style="list-style-type: none"> <li>• Principles and methods of safe work execution</li> <li>• The purposes, uses, care and maintenance of all equipment together with their safety implications</li> <li>• Environmental and safety principles and applications with regard to good housekeeping in the work area</li> <li>• Principles of effective communication</li> <li>• Principles of effective collaboration</li> <li>• The scope and limits of one’s own and others’ roles, responsibilities, and duties, both individually and collectively</li> <li>• Parameters within which activities must be planned</li> </ul>	

Section		Relative importance (%)
	<ul style="list-style-type: none"> <li>Principles and techniques for time management</li> </ul>	
	<p>The individual shall be able to</p> <ul style="list-style-type: none"> <li>Prepare and maintain a safe, tidy, and efficient work area</li> <li>Prepare self for the tasks in hand, including full regard to health, safety, and environment</li> <li>Schedule work to maximize efficiency and minimize disruption</li> <li>Select and use all equipment and materials safely and in compliance with manufacturers' instructions</li> <li>Apply or exceed the health and safety standards applying to the environment, equipment, and materials</li> <li>Restore the work area to an appropriate state and condition</li> <li>Contribute to team performance both broadly and specifically</li> <li>Give and take feedback and support</li> </ul>	
<b>2</b>	<b>Communication and interpersonal skills</b>	<b>5</b>
	<p>The individual needs to know and understand:</p> <ul style="list-style-type: none"> <li>Organizational cultures and behaviours within business and industry</li> <li>The purposes and range of required documentation in paper and electronic forms</li> <li>The technical language associated with the occupation and sector</li> <li>The standards required for routine and exception reporting in oral, written, and electronic form</li> <li>Good practice in communication with clients, team members, and others</li> <li>The purposes and techniques for generating, maintaining, and presenting records for one's own and others' uses</li> </ul>	
	<p>The individual shall be able to:</p> <ul style="list-style-type: none"> <li>Interact with a range of business and industry, modelling professional conduct at all times</li> <li>Communicate by oral, written, and electronic means to ensure clarity, effectiveness, and efficiency</li> <li>Use a standard range of communication technologies</li> <li>Discuss complex technical principles and applications with others</li> <li>Use active listening and questioning techniques</li> <li>Read, interpret, and extract technical data and instructions from documentation in any available format</li> <li>Complete reports and respond to issues and questions arising</li> <li>Respond to clients' and personnel's needs face to face and indirectly</li> <li>Gather information and prepare documentation as required by the client and other individuals and groups</li> </ul>	

Section		Relative importance (%)
3	<b>Layout and design</b>	15
	<p>The individual needs to know and understand:</p> <ul style="list-style-type: none"> <li>• The principles and relevant applications of computing and electronics</li> <li>• The relevant practical applications of engineering science and technology</li> <li>• The relevant practical implications of physical principles and interrelationships</li> <li>• The principles and relevant applications of electrical engineering and pneumatics</li> <li>• The design, uses, repair and maintenance needs of relevant machinery and tools</li> <li>• The principles and applications of robots, robotic tools and equipment mounted on robots and in robotic cells</li> <li>• Principles and methods of systems analysis to determine how conditions, operations and the environment will affect outcomes</li> <li>• Principles and applications for incorporating and integrating robots within industrial systems, such as:               <ul style="list-style-type: none"> <li>◦ Payload settings</li> <li>◦ Reach studies</li> <li>◦ Motion optimization</li> <li>◦ Principles of CAD and offline simulation tools used for layout and design of robot systems</li> </ul> </li> </ul>	
	<p>The individual shall be able to:</p> <ul style="list-style-type: none"> <li>• Acquire and check instructions and guidance for given assignments</li> <li>• Identify and resolve areas of uncertainty within the parameters of the brief</li> <li>• Carry out initial systems design for given industrial applications</li> <li>• Inspect installation sites or use alternative methods to test the applicability of initial systems design</li> <li>• Optimize systems designs within the parameters of the given industrial applications</li> <li>• Incorporate the dimensioning of electrical and pneumatic systems</li> <li>• Determine the role of pneumatic engineering in the choice and connection of controls and activators</li> <li>• Carry out systems analyses for risk assessment</li> <li>• Itemize the requirements and implications of installation and integration in relation to               <ul style="list-style-type: none"> <li>◦ Robots, ancillary equipment, and tools</li> <li>◦ Human resources and time</li> <li>◦ Estimated impacts on production during installation</li> <li>◦ Estimated impacts on production following installation</li> <li>◦ Operating parameters and risk management</li> </ul> </li> </ul>	

Section		Relative importance (%)
	<ul style="list-style-type: none"> <li>• Present proposals for consideration and approval, and adjust as required</li> </ul>	
<b>4</b>	<b>Installation and connectivity</b>	<b>15</b>
	<p>The individual needs to know and understand:</p> <ul style="list-style-type: none"> <li>• The norms and cultures of the receiving industrial sites</li> <li>• Principles and methods for the safe receipt and ongoing management of equipment, tools, and materials</li> <li>• Principles underlying the physical installation of robotics into production systems</li> <li>• Principles and methods for assembling pre-manufactured robots in their positions for use</li> <li>• Principles and methods for assembling and fixing tools and equipment to the robots</li> <li>• Principles underlying the positioning, connection and use of electrical power</li> <li>• Principles underlying the positioning, connection and use of pneumatics</li> <li>• Principles underlying the correct foundations and fixing methods required for installation of industrial robots and peripheral equipment</li> </ul>	

Section		Relative importance (%)
	<p>The individual shall be able to:</p> <ul style="list-style-type: none"> <li>• Check that all items have been delivered according to specification, and follow up as required</li> <li>• Organize the safe storage of all items, together with arrangements for their checking in and out</li> <li>• Check that the pre-manufactured robot has been delivered ready to run, and follow up as required</li> <li>• Connect robot system components according to instructions and documentation</li> <li>• Assemble, position, and fix robotic tools and equipment according to instructions and documentation</li> <li>• Align, fit, or assemble components, using hand tools, power tools, fixtures, or templates, according to specification</li> <li>• Liaise with specialists for the correct electrical, pneumatic, and mechanical installation of robots and peripheral equipment</li> <li>• Connect Input/Output (I/O) control signals between robot and peripheral equipment, either low voltage (24V) or Ethernet/Bus systems.</li> <li>• Perform tests during the installation process to ensure functionality</li> <li>• Identify installation issues, consider alternative solutions, and implement selected solution(s) to resolve the issues</li> <li>• Respect and take account of the receiving sites' requirements and characteristics, within the bounds of safe working, active risk management, and professionalism</li> </ul>	

Section		Relative importance (%)
<b>5</b>	<b>Automation and programming</b>	<b>25</b>
	<p>The individual needs to know and understand:</p> <ul style="list-style-type: none"> <li>• Computer capabilities and symbolic logic</li> <li>• Principles governing the purposes and functions of computer hardware and software</li> <li>• Principles and options for               <ul style="list-style-type: none"> <li>◦ Manipulating robot coordinate frames, for robot, cell, and tooling</li> <li>◦ Controlling robot motion</li> <li>◦ Controlling robot input/output (I/O) functions</li> <li>◦ Optimizing the user interface and</li> <li>◦ Enabling re-programming and adjustment</li> </ul> </li> <li>• The principles, reasons or facts that provide the basis for breaking down information or data into separate parts</li> <li>• Methods for obtaining information and data from all relevant sources</li> <li>• Principles and methods for processing information and data</li> <li>• The software in use</li> <li>• Sensor integration               <ul style="list-style-type: none"> <li>◦ Simple digital/electrical sensors</li> <li>◦ Advanced sensors such as Vision or Force sensors</li> </ul> </li> </ul>	
	<p>The individual shall be able to:</p> <ul style="list-style-type: none"> <li>• Consult with client/personnel to clarify program intent</li> <li>• Develop diagrams or flow charts of systems operations</li> <li>• Write, analyse, review and rewrite programs, using flow charts and diagrams</li> <li>• Create application software programs that are easy to document, understand and maintain</li> <li>• Conduct trial runs of programs and software applications to ensure they will produce the desired robot and cell performance</li> <li>• Write, update, and maintain computer programs or software packages to handle specific jobs</li> <li>• Optimize robot motion performance and I/O handling to minimize cycle time/maximize throughput while retaining reliable operation</li> <li>• Correct errors by making appropriate changes and rechecking the program to ensure that the desired results are produced</li> <li>• Consult with other personnel to identify problems and suggest changes</li> <li>• Implement new additional software and hardware options based on standard functionality</li> <li>• Integrate simple and advanced sensors</li> </ul>	
<b>6</b>	<b>Commissioning, maintenance, and troubleshooting</b>	<b>25</b>
	<p>The individual needs to know and understand:</p> <ul style="list-style-type: none"> <li>• The formal requirements for successful site acceptance tests</li> </ul>	

Section		Relative importance (%)
	<ul style="list-style-type: none"> <li>• The scope and limits of the technologies, methods operational environment</li> <li>• Criteria and methods for testing equipment and systems</li> <li>• Strategies for fault finding, problem solving, and optimization</li> <li>• Techniques and options for replacements and repairs</li> <li>• Principles and techniques for generating creative and innovative solutions</li> <li>• Principles and options for establishing and maintaining production maintenance regimes</li> </ul>	
	<p>The individual shall be able to:</p> <ul style="list-style-type: none"> <li>• Investigate whether the robot and its peripheral equipment are responding to the programmes' instructions</li> <li>• Revise, repair or expand existing programmes to increase operational efficiency or adapt to new requirements</li> <li>• Repair or replace components as required</li> <li>• Develop Human-Machine-Interface (HMI) applications for the users of the robot system, using HTML or other web technologies</li> <li>• Advise on maintenance regimes to maximize efficiency and minimize disruption</li> </ul>	
<b>7</b>	<b>Documentation, briefing, and reporting</b>	<b>10</b>
	<p>The individual needs to know and understand:</p> <ul style="list-style-type: none"> <li>• The role and importance of maintaining records of each stage of activity</li> <li>• The required media and formats of records and reports to ensure compliance with contracts, regulations and legislation, verification, and audit</li> <li>• The needs of users and specialists for information, guidance, and instructions in suitable forms (media, content, language, format, and presentation)</li> <li>• Clients' specific information needs</li> <li>• Basic principles and techniques for briefing and training non-specialist end users</li> <li>• Principles and techniques for critical review of own and others' performance.</li> <li>• Principles of common PC/Office software</li> </ul>	
	<p>The individual shall be able to:</p> <ul style="list-style-type: none"> <li>• Liaise with other personnel or departments for project integration</li> <li>• Document design and development procedures according to requirements</li> <li>• Compile and write documentation of program development and subsequent revisions, inserting comments in the coded instructions so that others can understand the computer programs</li> <li>• Present and provide test results from the commissioning process</li> </ul>	

Section		Relative importance (%)
	<ul style="list-style-type: none"> <li>• Design or contribute to instructions and guidance to guide end users, with an emphasis on clarity and ease of use</li> <li>• Provide the end user with a set of documentation in appropriate formats, including all necessary robot data such as:               <ul style="list-style-type: none"> <li>◦ Operating instructions</li> <li>◦ Application specific fault messages - I/O Listings</li> <li>◦ User adjustable parameter (register) descriptions</li> </ul> </li> <li>• Review each part of the process of design, fabrication and assembly, and operation, against established criteria, including accuracy, consistency, time, and cost</li> <li>• Contribute to individual and collective quality and contract review, responding to questions and challenges appropriately</li> </ul>	
	<b>Total</b>	<b>100</b>

## 3 The Assessment Strategy and Specification

### 3.1 General guidance

Assessment is governed by the WorldSkills Assessment Strategy. The Strategy establishes the principles and techniques to which WorldSkills assessment and marking must conform.

Expert assessment practice lies at the heart of the WorldSkills Competition. For this reason, it is the subject of continuing professional development and scrutiny. The growth of expertise in assessment will inform the future use and direction of the main assessment instruments used by the WorldSkills Competition: the Marking Scheme, Test Project, and Competition Information System (CIS).

Assessment at the WorldSkills Competition falls into two broad types: Measurement and Judgement. For both types of assessment, the use of explicit benchmarks against which to assess each Aspect is essential to guarantee quality.

The Marking Scheme must follow the weightings within the Standards. The Test Project is the assessment vehicle for the skill competition, and therefore also follows the Standards. The CIS enables the timely and accurate recording of marks; its capacity for scrutiny, support, and feedback is continuously expanding.

The Marking Scheme, in outline, will lead the process of Test Project design. After this, the Marking Scheme and Test Project will be designed, developed, and verified through an iterative process, to ensure that both together optimize their relationship with the Standards and the Assessment Strategy. They will be agreed by the Experts and submitted to WSI for approval together, to demonstrate their quality and conformity with the Standards.

Prior to submission for approval to WSI, the Marking Scheme and Test Project will liaise with the WSI Skill Advisors for quality assurance and to benefit from the capabilities of the CIS.

## 4 Assessment Design and Practice

### 4.1 General guidance

This section describes the role and place of the Marking Scheme, how the Experts will assess Competitors' work as demonstrated through the Test Project, and the procedures and requirements for marking.

The Marking Scheme is the pivotal instrument of the WorldSkills Competition, in that it ties assessment to the standard that represents each skill competition, which itself represents a global occupation. It is designed to allocate marks for each assessed aspect of performance in accordance with the weightings in the Standards.

By reflecting the weightings in the Standards, the Marking Scheme establishes the parameters for the design of the Test Project. Depending on the nature of the skill competition and its assessment needs, it may initially be appropriate to develop the Marking Scheme in more detail as a guide for Test Project design. Alternatively, initial Test Project design can be based on the outline Marking Scheme. From this point onwards the Marking Scheme and Test Project should be developed together.

Section 2.1 above indicates the extent to which the Marking Scheme and Test Project may diverge from the weightings given in the Standards, if there is no practicable alternative.

For integrity and fairness, the Marking Scheme and Test Project are increasingly designed and developed by one or more Independent Test Project Designer(s) with relevant expertise. In these instances, the Marking Scheme and Test Project are unseen by Experts until immediately before the start of the skill competition, or competition module. Where the detailed and final Marking Scheme and Test Project are designed by Experts, they must be approved by the whole Expert group prior to submission for independent validation and quality assurance. Please see the Competition Rules for further details.

Experts and Independent Test Project Designers are required to submit their Marking Schemes and Test Projects for review, verification, and validation well in advance of completion. They are also expected to work with their Skill Advisor, reviewers, and verifiers, throughout the design and development process, for quality assurance and in order to take full advantage of the CIS's features.

In all cases a draft Marking Scheme must be entered into the CIS at least eight weeks prior to the Competition. Skill Advisors actively facilitate this process.

### 4.2 Assessment Criteria

The main headings of the Marking Scheme are the Assessment Criteria. These headings are derived before, or in conjunction with, the Test Project. In some skill competitions the Assessment Criteria may be similar to the section headings in the Standards; in others they may be different. There will normally be between five and nine Assessment Criteria. Whether or not the headings match, the Marking Scheme as a whole must reflect the weightings in the Standards.

Assessment Criteria are created by the person or people developing the Marking Scheme, who are free to define the Criteria that they consider most suited to the assessment and marking of the Test Project. Each Assessment Criterion is defined by a letter (A-I). **The Assessment Criteria, the allocation of marks, and the assessment methods, should not be set out within this Technical Description. This is because the Criteria, allocation of marks, and assessment**

methods all depend on the nature of the Marking Scheme and Test Project, which is decided after this Technical Description is published.

The Mark Summary Form generated by the CIS will comprise a list of the Assessment Criteria and Sub Criteria.

The marks allocated to each Criterion will be calculated by the CIS. These will be the cumulative sum of marks given to each Aspect within that Assessment Criterion.

## 4.3 Sub Criteria

Each Assessment Criterion is divided into one or more Sub Criteria. Each Sub Criterion becomes the heading for a WorldSkills marking form. Each marking form (Sub Criterion) contains Aspects to be assessed and marked by Measurement or Judgement, or both Measurement and Judgement.

Each marking form (Sub Criterion) specifies both the day on which it will be marked, and the identity of the marking team.

## 4.4 Aspects

Each Aspect defines, in detail, a single item to be assessed and marked, together with the marks, and detailed descriptors or instructions as a guide to marking. Each Aspect is assessed either by Measurement or by Judgement.

The marking form lists, in detail, every Aspect to be marked together with the mark allocated to it. The sum of the marks allocated to each Aspect must fall within the range of marks specified for that section of the Standards. This will be displayed in the Mark Allocation Table of the CIS, in the following format, when the Marking Scheme is reviewed from C-8 weeks. (Section 4.1 refers.)

	CRITERIA								TOTAL MARKS PER SECTION	WSSS MARKS PER SECTION	VARIANCE	
	A	B	C	D	E	F	G	H				
STANDARDS SPECIFICATION SECTION	1	5.00								5.00	5.00	0.00
	2		2.00					7.50		9.50	10.00	0.50
	3								11.00	11.00	10.00	1.00
	4			5.00						5.00	5.00	0.00
	5				10.00	10.00	10.00			30.00	30.00	0.00
	6		8.00	5.00				2.50	9.00	24.50	25.00	0.50
	7			10.00				5.00		15.00	15.00	0.00
TOTAL MARKS	5.00	10.00	20.00	10.00	10.00	10.00	15.00	20.00	100.00	100.00	2.00	

## 4.5 Assessment and marking

There is to be one marking team for each Sub Criterion, whether it is assessed and marked by Judgement, Measurement, or both. The same marking team must assess and mark all Competitors. Where this is impracticable (for example where an action must be done by every Competitor simultaneously, and must be observed doing so), a second tier of assessment and marking will be put in place, with the approval of the Competitions Committee Management Team. The marking teams must be organized to ensure that there is no compatriot marking in any circumstances. (Section 4.6 refers.)

## 4.6 Assessment and marking using Judgement

Judgement uses a scale of 0-3. To apply the scale with rigour and consistency, Judgement must be conducted using:

- benchmarks (criteria) for detailed guidance for each Aspect (in words, images, artefacts, or separate guidance notes). This is documented in the Standards and Assessment Guide.
- the 0-3 scale to indicate:
  - 0: performance below industry standard
  - 1: performance meets industry standard
  - 2: performance meets and, in specific respects, exceeds industry standard
  - 3: performance wholly exceeds industry standard and is judged as excellent

Three Experts will judge each Aspect, normally simultaneously, and record their scores. A fourth Expert coordinates and supervises the scoring, and checks their validity. They also act as a judge when required to prevent compatriot marking.

## 4.7 Assessment and marking using Measurement

Normally three Experts will be used to assess each Aspect, with a fourth Expert supervising. In some circumstances the team may organize itself as two pairs, for dual marking. Unless otherwise stated, only the maximum mark or zero will be awarded. Where they are used, the benchmarks for awarding partial marks will be clearly defined within the Aspect. To avoid errors in calculation or transmission, the CIS provides a large number of automated calculation options, the use of which is mandated.

## 4.8 The use of Measurement and Judgement

Decisions regarding the choice of criteria and assessment methods will be made during the design of the competition through the Marking Scheme and Test Project.

## 4.9 Skill assessment strategy and procedures

WorldSkills is committed to continuous improvement including reviewing past limitations and building on good practice. The following skill assessment strategy and procedures for this skill competition take this into account and explain how the marking process will be managed.

The Competition Information System (CIS) will perform the calculations required for the allocation of time points.

Competitors may not modify cell components in any way during the competition. Exceptions are announced by the Skill Competition Manager or the Chief Expert.

The Sponsor support team provides spare and replacement parts to Competitors only during competition time. Exceptions are announced by the Skill Competition Manager or the Chief Expert.

Assessment “best practices and procedures” are described in the Standards and Assessment Guide which can be found on the WorldSkills website.

Both Competitors being assessed have to be present during the entire assessment procedure.

Experts should avoid using robot Teach Pendant or Controller (including I/O) or laptop, or touching Competitor’s installation, to avoid any possible interference with Competitor’s work.

Experts should ask Competitors to show them running cycles, robot setup, simulation, and/or documentation, and assess based on what they are shown, rather than investigating themselves and therefore risking interference in the Competitor's work.

Basic working style and safety should be recorded and assessed every day.

## 5 The Test Project

### 5.1 General notes

Sections 3 and 4 govern the development of the Test Project. These notes are supplementary.

Whether it is a single entity, or a series of stand-alone or connected modules, the Test Project will enable the assessment of the applied knowledge, skills, and behaviours set out in each section of the WSOS.

The purpose of the Test Project is to provide full, balanced, and authentic opportunities for assessment and marking across the Standards, in conjunction with the Marking Scheme. The relationship between the Test Project, Marking Scheme, and Standards will be a key indicator of quality, as will be its relationship with actual work performance.

The Test Project will not cover areas outside the Standards or affect the balance of marks within the Standards other than in the circumstances indicated by Section 2. This Technical Description will note any issues that affect the Test Project's capacity to support the full range of assessment relative to the Standards. Section 2.1 refers.

The Test Project will enable knowledge and understanding to be assessed solely through their applications within practical work. The Test Project will not assess knowledge of WorldSkills rules and regulations.

Most Test Projects and Marking Schemes are now designed and developed independently of the Experts. They are designed and developed either by the Skill Competition Manager, or an Independent Test Project Designer, normally from C-12 months. They are subject to independent review, verification, and validation. (Section 4.1 refers.)

The information provided below will be subject to what is known at the time of completing this Technical Description, and the requirement for confidentiality.

Please refer to the current version of the Competition Rules for further details.

### 5.2 Format/structure of the Test Project

Completion of a Robot System Integration project, through all steps from planning through implementation to documentation will use a realistic Test Project based on the FANUC Education Cell.

The Test Project is presented to the Competitors in the form of a project specification from an Industrial Customer.

### 5.3 Test Project design requirements

Test Projects should reflect the purposes, structures, processes, and outcomes of the occupational role they are based on. They should aim to be a small-scale version of that role. Before focusing on practicalities, SMTs should show how the Test Project design will provide full, balanced, and authentic opportunities for assessment and marking across the Standards, as set out in Section 5.1.

Overall, the Test Project must:

- Be modular, consisting of linked tasks to create a basic project and with additional tasks/modules which will result in an excellent project if completed during the Competition;

- Be accompanied by a Marking Scheme that is finalized at the Competition in accordance with section 3;
- The Test Project may include software or hardware functions which have not been disclosed to the Experts or Competitors in advance, to test the ability of Competitors to understand and use these under pressure;
- Be supplied with documentation clarifying the operation of special or new robot hardware or software functions for the Experts and Competitors, as well as the standard robot reference manuals.
- Test Project should include Background Material – Presentation/Pictures/Videos – showing how Test Project relates to real Industrial Robot applications.
- The Test Project should include speed and fault finding modules run in parallel to the main competition tasks. It is necessary to take precautions against loss of confidentiality of the S/FF modules, by having separate closed-off areas for the S/FF modules and an independent marking team.

#### Roboguide/Digital Twin:

- Simulation plays an important role in this skill.
  - Planning the layout of the cell and checking reachability of cell components.
  - Creating the basic task programme structure while the equipment is being installed according to the layout
  - Creating the extension task programme structure while the basic task structure is being installed and tested
- It is also important that any changes that are found during installation and testing are implemented in the simulation as well as on the real cell – so that there is a Digital Twin of the actual cell – the layout, the programmes – all aspects of the cell.
- Competitors will first be asked to create a Roboguide programme to check reachability of the components in the cell. Later it will be checked if the Roboguide simulation is really a Digital Twin of the real cell.
- Competitors should make the Teach Pendant display as realistic as possible – for example with the 4D Graphics function.
- Competitors should work professionally with the laptop as well as with the robot.

#### Documentation:

- When Competitors have finished the task, they should hand over a documentation package to the end customer. This documentation should contain all the information necessary to run, maintain, and troubleshoot the cell after they leave site.
- Competitors are provided with a template document in English for the documentation package.
- The contents by the Competitors does not need to be in English, but it would help the marking teams if at least the titles of the different sections of the documentation could be in English and own language, and it is recommended that documentation is in English if possible. Writing style, spelling, and grammar are not assessed.

## 5.4 Test Project coordination and development

The Test Project **MUST** be submitted using the templates provided by WorldSkills International ([www.worldskills.org/expertcentre](http://www.worldskills.org/expertcentre)). Use the Word template for text documents and DWG template for drawings.

### 5.4.1 Test Project coordination (preparation for Competition)

Coordination of the Test Project/modules will be undertaken by the Skill Competition Manager.

#### 5.4.2 Who develops the Test Project/modules

The Test Project/modules are developed by an Independent Test Project Designer (ITPD) in collaboration with the Skill Competition Manager.

#### 5.4.3 When is the Test Project developed

The Test Project/modules are developed according to the following timeline:

Time	Action
Fifteen (15) months prior to the Competition	The ITPD is identified and a Confidentiality Agreement between WSI and the ITPD is organized.
No later than two (2) months prior to the Competition	The Test Project documents are sent to the WorldSkills International Skills Competitions Administration Manager.
At the Competition	If undisclosed software or hardware is included in the Test Project as part of the competition, the relevant documentation is supplied to Competitors to use during competition.
At the Competition on C-2	The generic Test Project/modules are presented to Experts and Competitors, without technical instructions.
At the Competition at the beginning of each module	Instructions on the Test Project/modules are presented to Competitors.

### 5.5 Test Project initial review and verification

The purpose of a Test Project is to create a challenge for Competitors which authentically represents working life for an outstanding practitioner in an identified occupation. By doing this, the Test Project will apply the Marking Scheme and fully represent the WSOS. In this way it is unique in its context, purpose, activities, and expectations.

To support Test Project design and development, a rigorous quality assurance and design process is in place (Competition Rules sections 10.6-10.7 refer.) Once approved by WorldSkills, the Independent Test Project Designer (ITPD) is expected to identify one or more independent expert(s), and trusted individuals initially to review the Independent Test Project Designer's ideas and plans, and subsequently to verify the Test Project, prior to validation.

A Skill Advisor will ensure and coordinate this arrangement, to guarantee the timeliness and thoroughness of both initial review, and verification, based on the risk analysis that underpins Section 10.7 of the Competition Rules.

### 5.6 Test Project validation

The Skill Competition Manager coordinates the validation of the Test Project/modules and will ensure that it can be completed within the material, equipment, knowledge, and time constraints of Competitors.

## 5.7 Test Project circulation

The Test Project/modules are not circulated prior to the Competition. The generic Test Project/modules without technical instructions are presented to Experts and Competitors on C-2.

Specific instructions on the Test Project/modules are presented to Competitors at the beginning of each module.

If translation is required, documents are first machine translated and then given to Interpreters for checking. This checking is done immediately before the instructions are given out to all Competitors to prevent loss of confidentiality.

## 5.8 Test Project change

Due to the Test Project being developed by an Independent Test Project Designer (ITPD), there is no change required to be made to the Test Project/modules at the Competition. Exceptions are amendments to technical errors in the Test Project documents and according to infrastructure limitations.

## 5.9 Material or manufacturer specifications

Specific material and/or manufacturer specifications required to allow the Competitor to complete the Test Project will be supplied by the Competition Organizer and are available from [www.worldskills.org/infrastructure](http://www.worldskills.org/infrastructure) located in the Expert Centre. However, note that in some cases details of specific materials and/or manufacturer specifications may remain secret and will not be released prior to the Competition. These items may include those for fault finding modules or modules not circulated.

The Global Partner will supply all necessary documentation, manuals etc. in electronic form.

Competitor PC Software and Internet Access

- Competitors are provided with PCs for Simulation, Robot Setup, User Interface development etc.
- All necessary software is pre-installed on these PCs, and it is forbidden to install any additional software
- These PCs are provided with an Ethernet cable to connect to the Robot Controller, and it is forbidden to make any additional connection via Ethernet or Wi-Fi. Internet access is forbidden.

Documentation and Manuals

- Details of the latest version of the Global Partner Robot Equipment is circulated six (6) months prior to the Competition on the WorldSkills Discussion Forum
- The documentation for all software and hardware options used in the Test Projects is circulated three (3) months prior to the Competition on the WorldSkills Discussion Forum.
- Manuals are only required/supplied in English.

## 6 Skill management and communication

### 6.1 Discussion Forum

Prior to the Competition, all discussion, communication, collaboration, and decision making regarding the skill competition must take place on the WorldSkills skill-specific Discussion Forum. (<http://forums.worldskills.org>). Skill related decisions and communication are only valid if they take place on the WorldSkills Discussion Forum. The Chief Expert (or an Expert Lead appointed by the Skill Management Team) will be the moderator for this Discussion Forum. Refer to the Competition Rules for the timeline of communication and competition development requirements.

### 6.2 Competitor information

All information for registered Competitors is available from the Competitor Centre ([www.worldskills.org/competitorcentre](http://www.worldskills.org/competitorcentre)).

This information includes:

- Competition Rules
- Technical Descriptions
- Mark Summary Form (where applicable)
- Test Projects (where applicable)
- Infrastructure List
- WorldSkills Health, Safety, and Environment Policy and Regulations
- Other Competition-related information

### 6.3 Test Projects and Marking Schemes



Circulated Test Projects will be available from [www.worldskills.org/testprojects](http://www.worldskills.org/testprojects) and the Competitor Centre ([www.worldskills.org/competitorcentre](http://www.worldskills.org/competitorcentre)).

### 6.4 Day-to-day management

The day-to-day management of the skill competition during the Competition is defined in the Skill Management Plan that is created by the Skill Management Team. The Skill Management Team comprises the Skill Competition Manager, Chief Expert, and the Expert Leads. The Skill Management Plan is progressively developed in the six (6) months prior to the Competition and finalized at the Competition. The Skill Management Plan can be viewed in the Expert Centre ([www.worldskills.org/expertcentre](http://www.worldskills.org/expertcentre)).

### 6.5 General best practice procedures

General best practice procedures clearly delineate the difference between what is a best practice procedure and skill-specific rules (section 9). General best practice procedures are those where Experts and Competitors CANNOT be held accountable as a breach to the Competition Rules or skill-specific rules which would have a penalty applied as part of the Issue and Dispute Resolution procedure including the Code of Ethics and Conduct Penalty System. In some cases, general best practice procedures for Competitors may be reflected in the Marking Scheme.

Topic/task	Best practice procedure
Competitor PC connectivity	<ul style="list-style-type: none"> <li>• Competitor PCs are to be connected via Ethernet to the robot controller only.</li> <li>• All other Ethernet or Wi-Fi connections are prohibited and should be disabled prior to the start of the competition.</li> <li>• PC software must be able to run stand-alone, without needing access to Internet – for instance for licensing.</li> </ul>
Competitor PC security	<ul style="list-style-type: none"> <li>• It must be ensured that neither the Competitors nor anyone else have access to the PCs outside of Competition hours.</li> <li>• An example implementation of this is to store the Competitor PCs in the tool trolley with two locks. The key for one lock is held by the Competitors or their compatriot Expert. The key for the other lock is held by the Skill Competition Manager or the Chief Expert.</li> </ul> 
Robot Controller security	<ul style="list-style-type: none"> <li>• It must be ensured that neither the Competitors nor anyone else have access to the Robot Controller outside of Competition hours.</li> <li>• An example of this is to lock the Robot Controller in the power OFF position with the key secured in the same manner as the Competitor PCs.</li> </ul> 
Supervision/ Marking of Safety Issues	Basic Working Style and Safety should be recorded & marked every day
	SMT should create an Expert Supervision Rota for C1-C4 to ensure that there are always enough Experts in the workshop to supervise the

Topic/task	Best practice procedure
Expert Supervision Rota	competition, while also allowing spare time for the Experts to follow up on their personal and professional activities and participate in the rest of the event.

## 7 Skill-specific safety requirements

### 7.1 Personal Protective Equipment

Refer to WorldSkills Safety Policy and Regulations for Host country or region regulations.

- It is not foreseen that the Test Project will include any electrical or mechanical assembly activities which require specific safety measures;
- Safe robot operating procedures must be followed. These must be reviewed with the Experts and Competitors at the start of the competition;
- The Experts are responsible for making sure that the Competitors follow the safe operating procedures;
- The design of the Education Cell ensures that the robot can only be operated in Automatic (100% speed) mode when the robot cell door is closed;

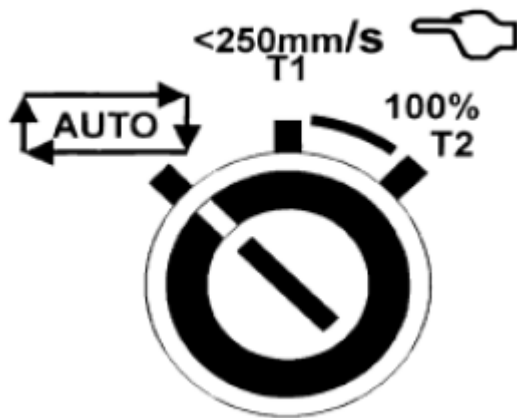

- Competitors should do all setup/programming etc. in T1 mode (<250 mm/s)
- For Testing, the Competitors can use Auto, T2 or T1 Mode.
- The use of T2 (100% speed with door open) mode is decided by the SMT for each competition;
- The method of ensuring correct use of the Auto/T1/T2 key and other safety measures must be agreed with the SMT prior to the Competition, for instance by:
  - indicating clearly by additional label on the robot controller.
  - giving the Experts the Auto/T1/T2 key
  - giving the Competitors responsibility for the Auto/T1/T2 key
- The Competitor's bodies must not enter the cell while moving the robot or manipulating the teach pendant.

*Examples:*

OK	OK
Body is outside of the cell while moving the robot.	Body is partially inside the cell, but TP is on hook



- The Competitors must always be able to take a step back when working in the cell or moving the robot in case something unexpected happens.

Examples:

OK

Not OK



- Controller Access/Open Controller Door

If there is a reason for the Competitors to open the controller door, this will be explicitly stated in the Test Project Description. Otherwise the controller door should remain closed.

But in case Competitors request, for instance to check a proper Ethernet connection, the door may be opened **by FANUC Technical Support Staff or two non-compatriot Experts only.**

**Power must be turned off before opening controller!**

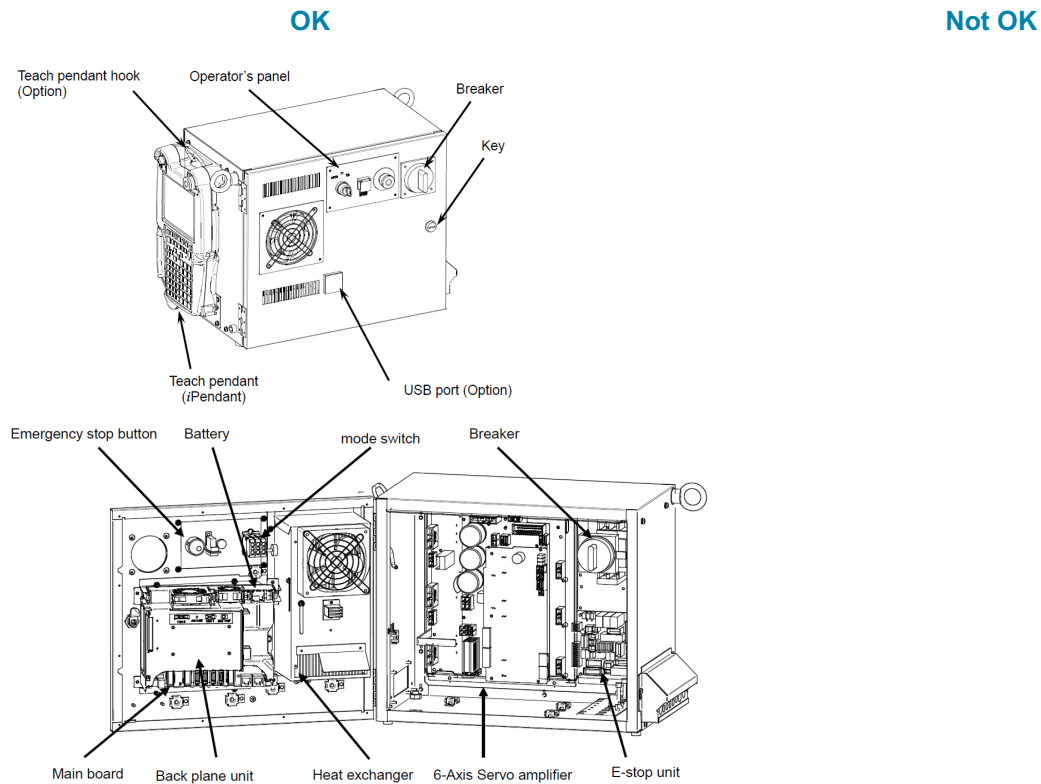

#### Robot and Laptop Power:

- At the end of every Day of competition, the Competitors should turn robot and PC power OFF. The Experts will tell the Competitors when to turn power ON again before marking.

Task	Safety glasses with side protection	Sturdy shoes with closed toe and no heel
General PPE for safe areas		√
General work at workstation		√
Competitor Work Areas	Safety glasses are required for all Competitors working inside the robot cell. Safety glasses are NOT required when robot cell door is closed.	Safety shoes are required for EVERYONE entering Competitor work areas



## 8 Materials and equipment

### 8.1 Infrastructure List

The Infrastructure List details all equipment, materials, and facilities provided by the Competition Organizer.

The Infrastructure List is available at [www.worldskills.org/infrastructure](http://www.worldskills.org/infrastructure).

The Infrastructure List specifies the items and quantities requested by the Skill Management Team for the next Competition. The Competition Organizer will progressively update the Infrastructure List specifying the actual quantity, type, brand, and model of the items. Note that in some cases details of specific materials and/or manufacturer specifications may remain secret and will not be released prior to the Competition. These items may include those for fault finding modules or modules not circulated.

At each Competition, the Skill Management Team must review and update the Infrastructure List in preparation for the next Competition. The Skill Competition Manager must advise the Director of Skills Competitions of any increases in space and/or equipment.

At each Competition, the Technical Observer must audit the Infrastructure List that was used at that Competition for the upcoming WorldSkills Competition.

The Infrastructure List does not include items that Competitors and/or Experts are required to bring and items that Competitors are not allowed to bring – they are specified below.

### 8.2 Competitors toolbox

Competitors are not allowed to send a toolbox to the Competition. All tools are provided by the Competition Organizer.

### 8.3 Materials, equipment, and tools supplied by Competitors

It is not applicable for Competitors to bring materials, equipment, and tools to the Competition.

However, Competitors are required to supply their own Personal Protective Equipment as specified in section 7 skill-specific safety requirements.

The Competitor PCs are equipped with US International standard keyboards and basic mouse.

Competitors may bring their own keyboard and mouse to connect to the PC if they prefer. Hard-wired USB connections are recommended. The installation and functioning of these devices are the responsibility of the Competitors. It is permitted to install additional drivers, if necessary, after approval by SMT.

Neither WorldSkills nor the Global Partner or PC supplier can guarantee the compatibility or functioning of the Competitor supplied devices.

Competitors may also bring a paper or electronic dictionary. The dictionary may not have been modified in any way (handwriting, additional papers etc.). It will be checked on C-2.

There should be no other tools or equipment required to complete the Test Project – these are all provided in the Test Project Kit and Tool Trolley, and Competitors are prohibited from bringing other tools and equipment.

## 8.4 Materials, equipment, and tools supplied by Experts

Experts are required to supply their own Personal Protective Equipment as specified in section 7 skill-specific safety requirements.

Experts are responsible that Interpreters bring their own PPE.

## 8.5 Materials and equipment prohibited in the skill area

Competitors and Experts are prohibited to bring any materials or equipment not listed in section 8.3 and section 8.4.

### Personal laptops, USB, memory sticks, mobile phones

- Competitors are only allowed to use memory sticks provided by the Competition Organizer.
- Memory sticks or any other portable memory devices cannot be taken outside the workshop.
- Memory sticks or other portable memory devices are to be submitted to the Chief Expert or to the Deputy Chief Expert at the end of each day for safe keeping.
- Experts are allowed to use personal laptops, tablets, and mobile phones in the Expert room only.
- Competitors are not allowed to bring personal laptops, tablets, or mobile phones into the workshop.

### Personal photo cameras and video taking devices

- Competitors and Experts are allowed to use personal photo and video taking devices in the workshop at the conclusion of the competition only.

## 8.6 Proposed workshop and workstation layouts

Workshop layouts from previous competitions are available at [www.worldskills.org/sitelayout](http://www.worldskills.org/sitelayout).

### Example workshop layout

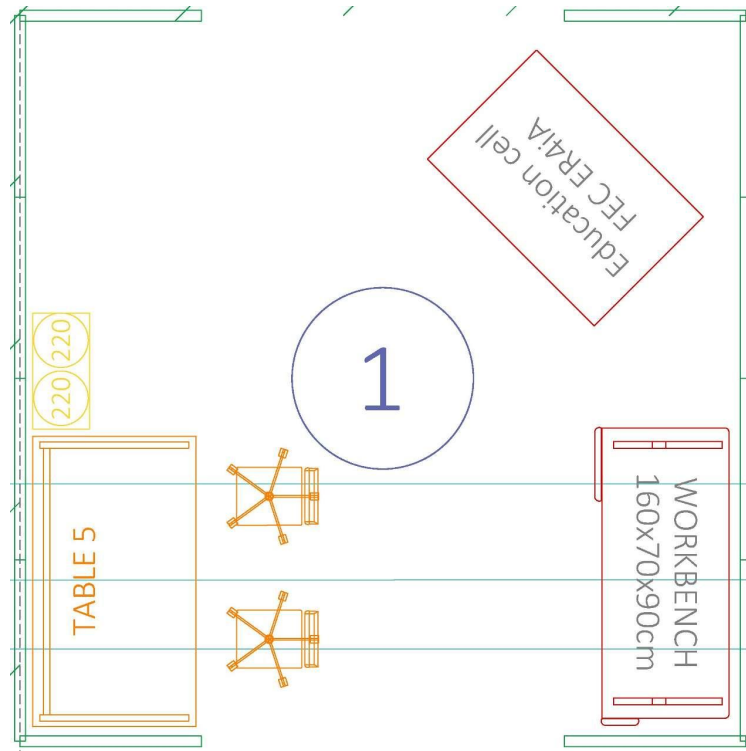
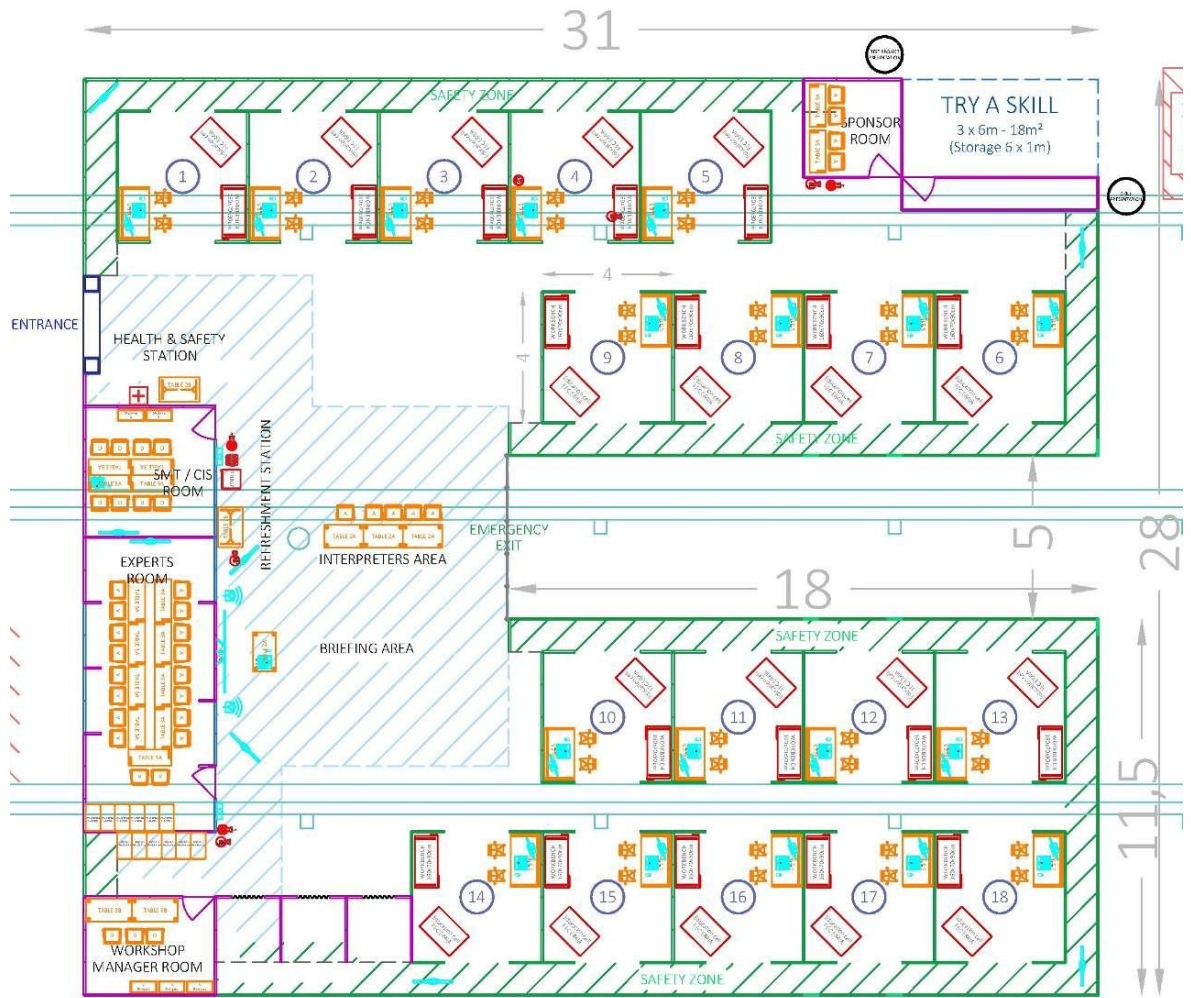

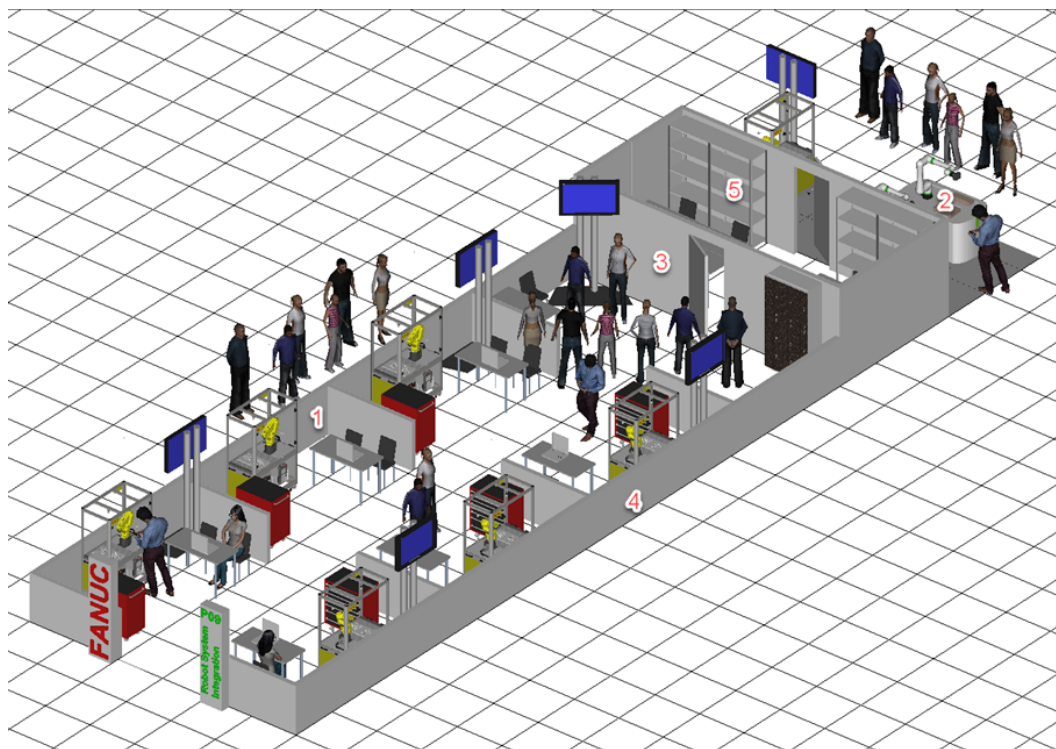

Total area shown approximately 10 m x 23 m

1	Five complete sets of competition equipment as shown in section above. Each team has a space of approx. 4 m x 5 m to provide some separation between the teams.
2	Public exhibition/engagement area where skill can be demonstrated to public and other interested parties
3	Experts area
4	Workshop is surrounded by low wall. Since each robot cell is self-contained and guarded, there is no need for special protection for spectators, so they can get close up to the competition cells. The cells have large transparent rear window allowing clear view for spectators.
5	Storage, Expert and Competitor Rooms, if required.

#### Standard FANUC Europe Education Cell

1	Robot
2	Controller
3	Teach Pendant
4	Schunk EGP40 Electric Gripper

5	iRVision Camera
---	-----------------

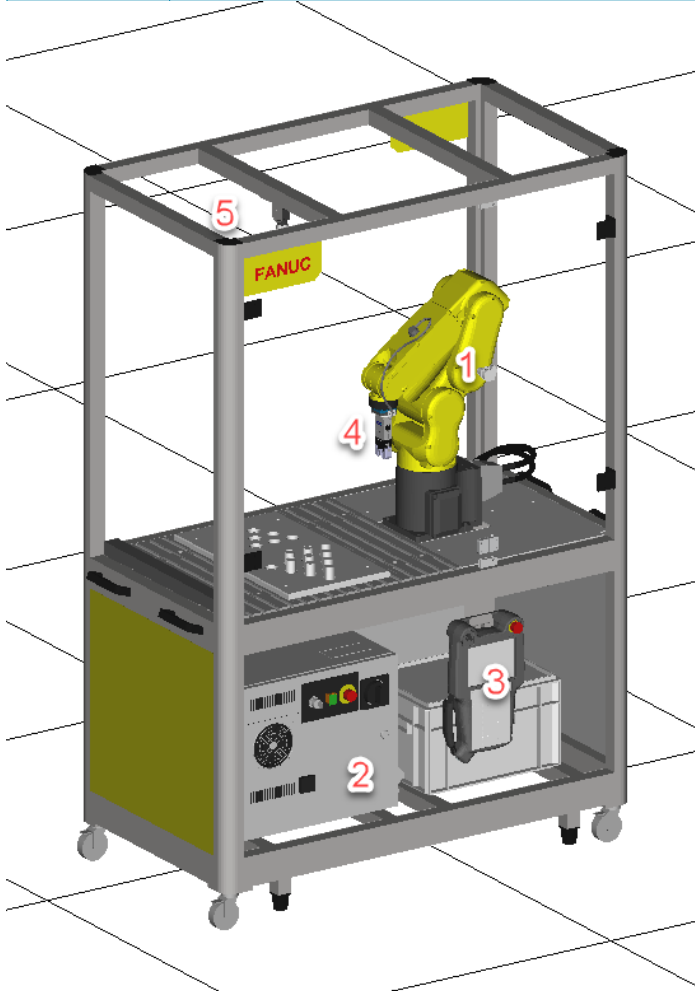

### FANUC Shanghai Education Cell

1	Robot
2	Controller
3	Teach Pendant
4	Schunk EGP40 Electric Gripper
5	iRVision Camera
6 /6B	Light Beam Safety

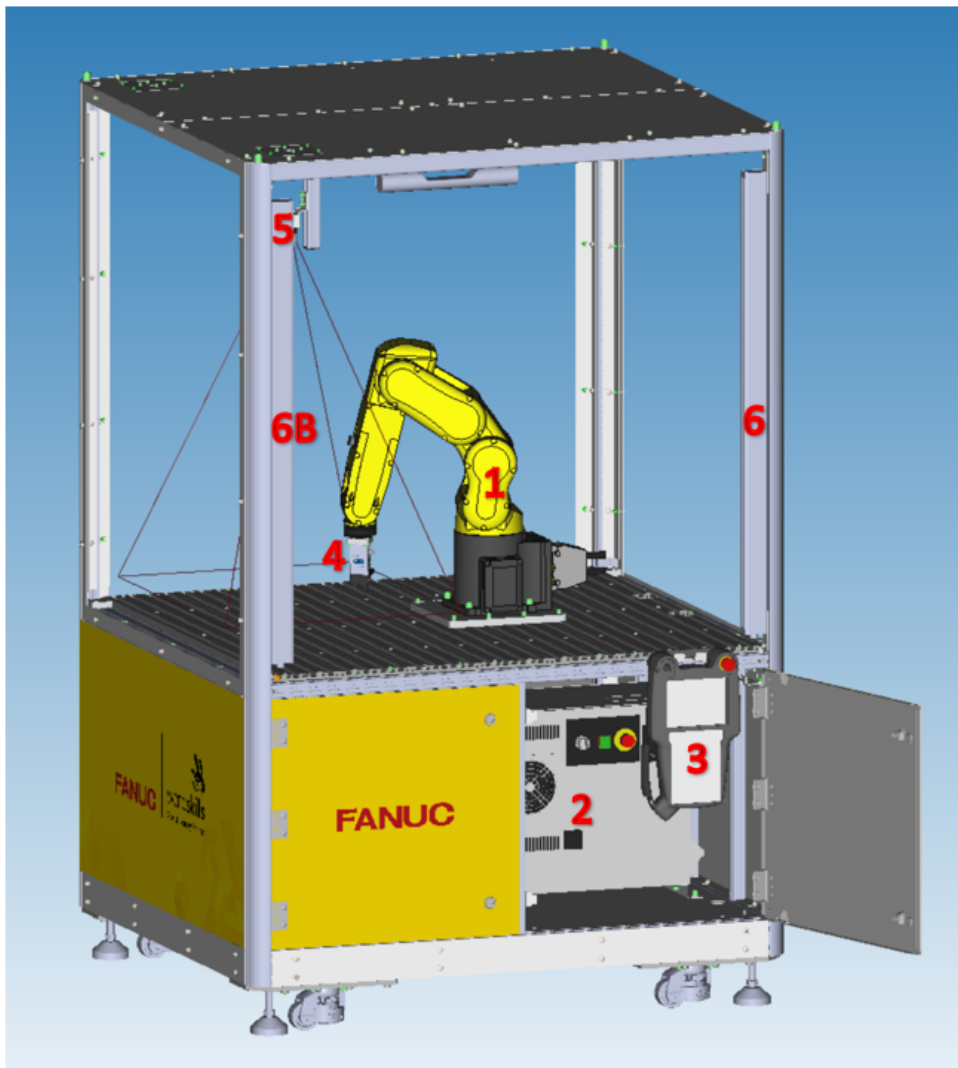

The cell uses the FANUC ER-4iA robot together with the latest generation R-30iB Mate Plus controller. The robot is equipped with integrated iRVision 2D camera system, and a Schunk EGP40 gripper.

The standard cell comes with full instructions and exercises which the Competitors can use to prepare themselves for the competition. The cell also comes with a running 'pick and place' application which is replaced for the competition.

### **Additional Equipment**

In addition to the FANUC Education Cell, some additional equipment is needed as shown below.

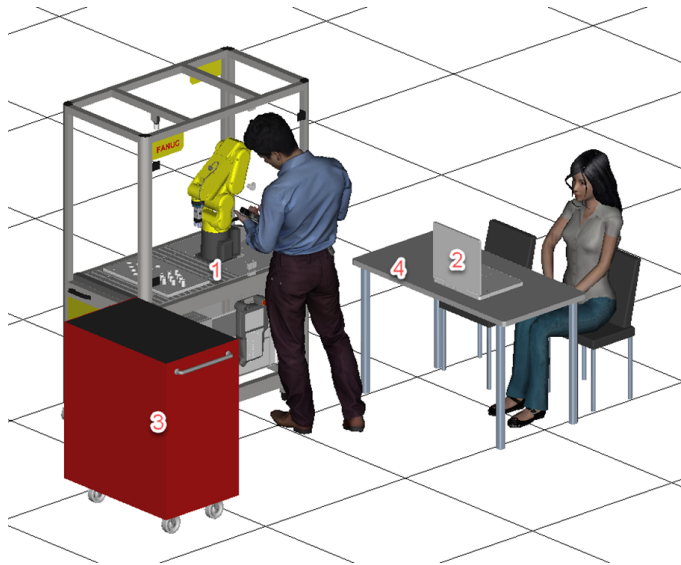

1	FANUC Education Cell, modified to support a Competition-specific Test Project
2	Laptop with pre-installed software: Roboguide/Sharepoint designer/Office etc
3	Tool Trolley - containing all necessary Tools and Test project equipment including storage of Competitors PC (see section 6.5)
4	Tables and chairs for the Competitors
5	Minimum space per team is 3 m x 4 m

### Wheelchair users

Most, but not all of the tasks can be carried out by Competitors in wheelchairs, for instance:

- Simulation/offline programming
- Robot/Vision System setup and programming
- Documentation
- Some of the electrical connections

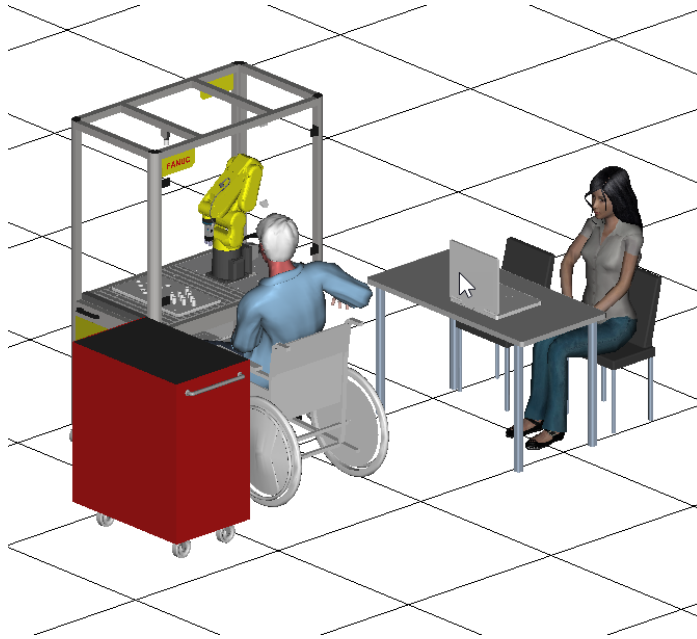

But other tasks such as mechanical installation inside the cell cannot be done from a wheelchair, so one team member could be in a wheelchair, but not both.

## 9 Skill-specific rules

### 9.1 General notes

Skill-specific rules cannot contradict or take priority over the Competition Rules. They do provide specific details and clarity in areas that may vary from skill competition to skill competition. This includes but is not limited to personal IT equipment, data storage devices, Internet access, procedures and workflow, and documentation management and distribution. Breaches of these rules will be solved according to the Issue and Dispute Resolution procedure including the Code of Ethics and Conduct Penalty System.

### 9.2 Skill-specific rules

Topic/task	Skill-specific rules
Use of technology – USB, memory sticks	<ul style="list-style-type: none"> <li>• Competitors are only allowed to use memory sticks provided by the Competition Organizer.</li> <li>• Memory sticks or any other portable memory devices cannot be taken outside the workshop.</li> <li>• Memory sticks or other portable memory devices are to be secured in the same manner as the Competitor PCs.</li> </ul>
Use of technology – personal laptops, tablets, and mobile phones	<ul style="list-style-type: none"> <li>• Experts and Interpreters are allowed to use personal laptops, tablets, and mobile phones in the Expert room only.</li> <li>• Competitors are not allowed to bring any electronic devices into the workshop or access during lunchtime without specific agreement from the Skill Competition Manager or the Chief Expert.</li> </ul>
Use of technology – personal cameras	<ul style="list-style-type: none"> <li>• Skill Competition Manager, Chief Expert, Experts, Competitors, and Interpreters are allowed to use personal photo and video taking devices in the workshop at the conclusion of the competition on C4 only.</li> </ul>
Mark Allocation	<ul style="list-style-type: none"> <li>• Safety and Task Completion should be most important issues. Task completion, including cycle time and precision/repeatability/reliability should be considered more important and assigned a larger percentage of total marks.</li> </ul>
Workpiece checking	<ul style="list-style-type: none"> <li>• Competitors should be responsible for making sure that all workpieces are correct during specified time during familiarization.</li> <li>• Competitors should be provided with Vernier callipers to check dimensions by themselves.</li> </ul>
Workshop Clock	<ul style="list-style-type: none"> <li>• Ideally Workshop clock should be provided with following features:               <ul style="list-style-type: none"> <li>◦ Actual Time</li> <li>◦ Countdown Time to end of current session</li> </ul> </li> </ul>

Topic/task	Skill-specific rules
	<ul style="list-style-type: none"> <li>◦ Any additional time for individual teams (for instance in case of additional time granted because of equipment malfunction)</li> <li>◦ Workshop clock should be easily visible for all Competitors from their workstations, or multiple clocks may be required.</li> </ul>
Part replacement	<ul style="list-style-type: none"> <li>• Any broken parts on one day must be replaced – without awarding stop time - so that further damage on further days can be properly assessed.</li> </ul>
Test Running	<ul style="list-style-type: none"> <li>• During marking, the Competitors will be asked to test run the different Tasks that have been set. As in industry, Reliability and Cycle Time are both important.</li> <li>• The number of completed cycles and the cycle time will be marked separately. Marks will be given for cycle time only if all required cycles are completed.</li> <li>• The Competitors can choose Auto/T1/T2 mode and Override % and change during test run if desired.</li> <li>• During marking the Competitors have THREE attempts ONLY to demonstrate the full number of cycles.</li> <li>• The first successful attempt ends the marking, and the cycle time for that attempt will be used for the cycle time marking.</li> <li>• Competitors may change whatever programs, data, settings they want to in between attempts, but the maximum time allowed for all test runs will be set for each task, for example five minutes.</li> <li>• Please note that changing between test runs is a risky activity and competitors are encouraged to make sure that their systems are reliable and will run correctly first time.</li> </ul>

# 10 Expert knowledge and experience

## 10.1 Requirements

Experts appointed for this skill competition must have the following knowledge and experience for the appropriate occupation or work role as documented in **section 1.1.2**.

### Minimum qualification and/or industry/professional experience

- Vocational training in robotics, electrical engineering, automation, or mechanical engineering, or mechatronics. Alternatively: Technician or master's degree or a bachelor's or master's degree in robotics or a related engineering discipline
- At least 2–3 years in manufacturing, robotics manufacturer company, robotics system integration company, automation systems, or process control in industry or trade (e.g. plant installation, maintenance, control technology)

### Online Expert test

- Successful completion of the Online Expert Test is mandatory. Experts must be able to clearly explain and justify their answers to demonstrate personal understanding.

### English language proficiency

- English proficiency is essential but it is not a sticking point, it is recommended that experts train as much as possible before the competition and ask their national organization to have the support of an interpreter during the competition if necessary

### Teamwork and professional conduct

- Experts must demonstrate strong teamwork skills and professional behavior throughout the competition. A commitment to fairness, objectivity, and adherence to established rules and procedures is essential to ensure consistency and integrity.

### Mentorship and Pedagogical Skills

- During the preparation for the championship, Experts are expected to mentor and support competitors. Strong teaching and coaching abilities, along with a sound pedagogical approach, are highly valued.

### Technical and educational network

- For National championships and in the preparation of a competitor, access to relevant tools, software, and machine training resources is beneficial. The ability to leverage professional networks to support competitor preparation is an advantage.

### Commitment to youth development

- A genuine passion for supporting young people in skills development is essential. Empathy, patience, and dedication to their growth and success are key attributes.

### Familiarity with WorldSkills standards and procedures

- Experts should have a solid understanding of WorldSkills competition standards, assessment criteria, and procedural workflows, have been an Expert/judge in their Member's national/ regional competition minimum one Skill Competition

- Working knowledge of the CIS, development of the Test Project and Marking Scheme, and the WorldSkills Occupational Standards

#### **Safety and sustainability awareness**

- Knowledge of occupational safety standards and sustainable practices in robot system integration. Experts should promote safe working environments and resource-efficient processes.

#### **Conflict resolution and mediation skills**

- In case of disputes or misunderstandings during the competition, experts should be able to mediate constructively and maintain a calm, solution-oriented approach.

#### **Availability for pre-competition activities**

- Experts must be available for preparatory meetings, training sessions, and documentation tasks prior to the competition.
- This includes participation in the Expert Forum and Access Programme, Experts need to participate to the Mandatory Assessment Training organize online by the SMT before the competition.

#### **Cultural sensitivity and international collaboration**

- As WorldSkills is a global event, experts should be open to working with people from diverse cultural backgrounds and demonstrate respect and adaptability in international settings.

# 11 Visitor and media engagement

## 11.1 Engagement methods

Following is a list of possible ways to maximize visitor and media engagement:

- Display screens - some web cams could be dispatched on the Competition area and show details of the task to the public and on a website;
- Test Project descriptions;
- Enhanced understanding of Competitor activity;
  - Competitor profiles - For each Competitor team provide a sticker with the national flag, the name of the Competitor and a brief description of their studies;
  - Daily reporting of Competition status;
- Try-a-Skill - in the Robot System Integration workshop provide an area where young people and public can work with a Robot System – for instance a standard Education Cell. This activity could be managed by a students of from the Host Country/Region.
- Display videos of typical Robot Systems and Applications.
- Large Industrial Robot could be installed as an eye-catching static display

The back side of the Education Cell, opposite to the opening side where the Competitors work, is a full-size plexiglass window – see below. This allows spectators a complete view of the robot application, without any safety issues.



# 12 Sustainability

## 12.1 Sustainable practices

This skill competition will focus on the sustainable practices below:

- Recycling;
- Use of “green” materials;
- Test Project, Robot and equipment manuals etc. provided in electronic rather than paper form

## 13 References for industry consultation

### 13.1 General notes

WorldSkills is committed to ensuring that the WorldSkills Occupational Standards fully reflect the dynamism of internationally recognized best practice in industry and business. To do this WorldSkills approaches a number of organizations across the world that can offer feedback on the draft Description of the Associated Role and WorldSkills Occupational Standards on a two-yearly cycle.

In parallel to this, WSI consults three international occupational classifications and databases:

- ISCO-08: (<http://www.ilo.org/public/english/bureau/stat/isco/isco08/>)
- ESCO: (<https://ec.europa.eu/esco/portal/home> )
- O\*NET OnLine ([www.onetonline.org/](http://www.onetonline.org/))

### 13.2 References

This WSOS appears most closely to reflect Robotics Technician:

<https://www.onetonline.org/link/summary/17-3024.01>

And Robotics Engineering Technician:

<http://data.europa.eu/esco/occupation/7833d5cd-873d-4fdd-b2f8-9762d68494a7>

ISCO 3119

Unfortunately no feedback was received from business and industry for WorldSkills Shanghai 2026.

# 14 Appendix

## 14.1 Appendix information

Not applicable.