

C 石枠高さ

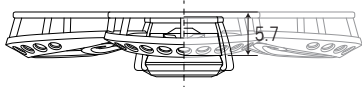

【上面図】

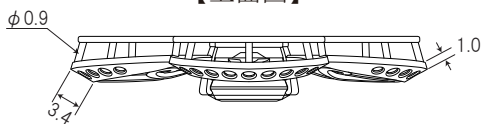

【正面図】

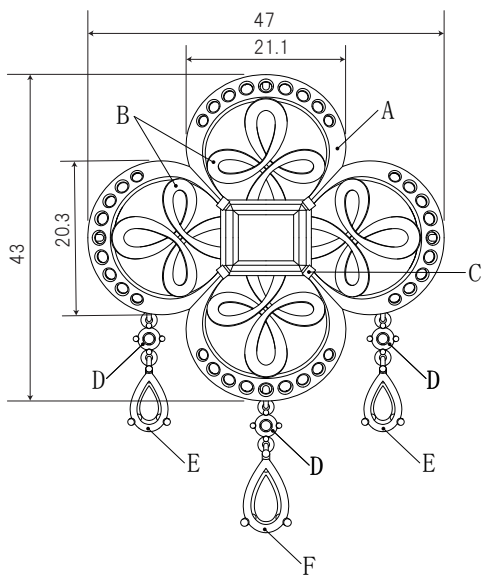

【右側面図】

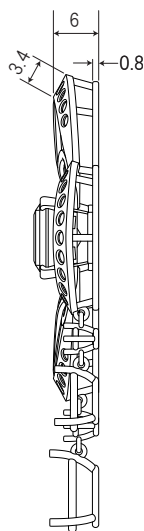

【背面図】

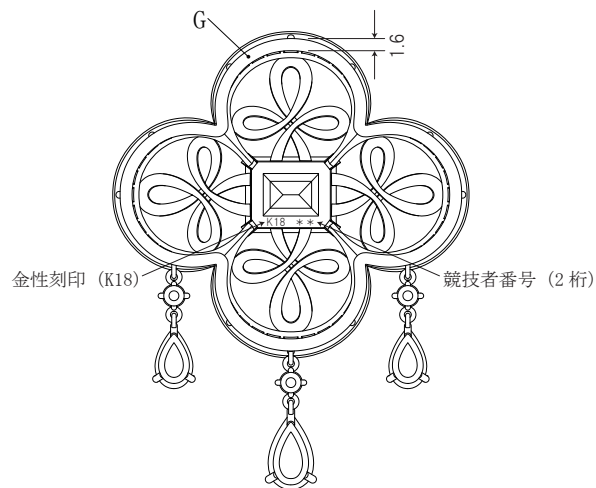

A メレ穴裏取り

※ 上面図は、D、E、F パーツは省略してあります。

尺度	1 : 1	
名称	ペンダント	
許容差	10mm未満	±0.05
	20mm未満	±0.3
	20mm以上	±0.5

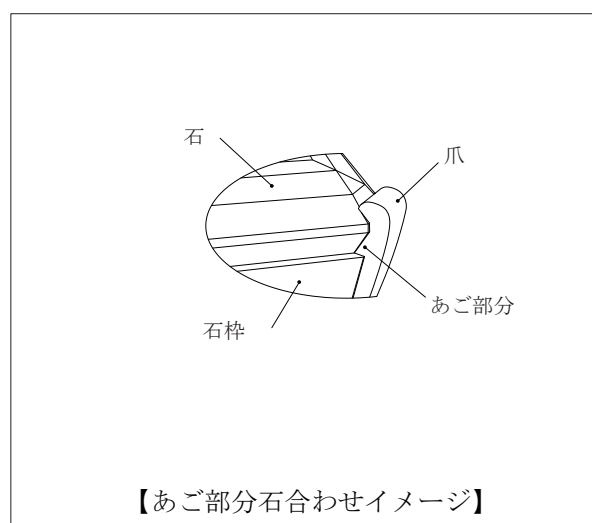
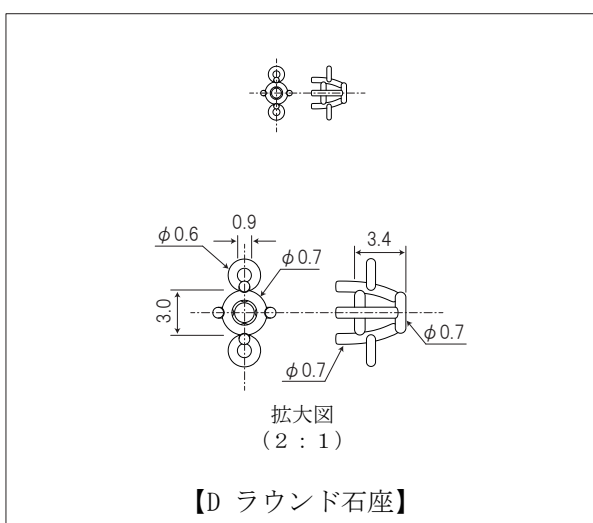
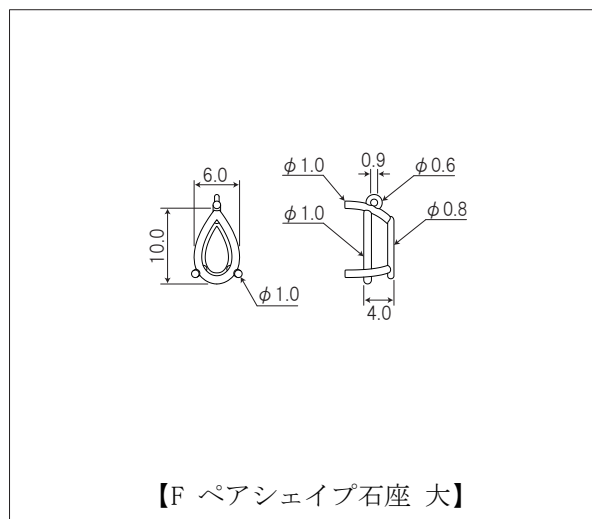
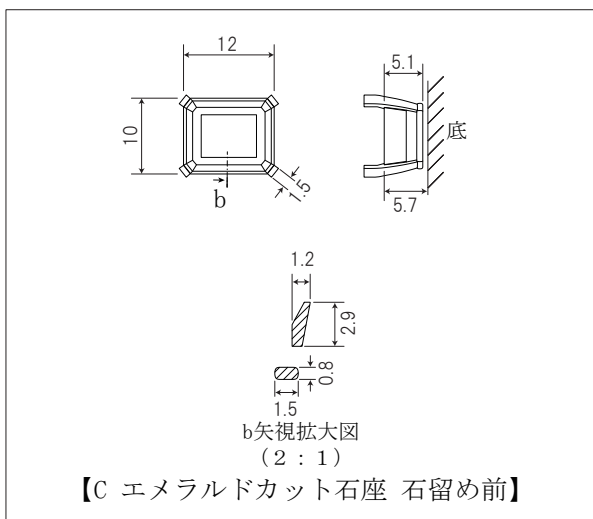
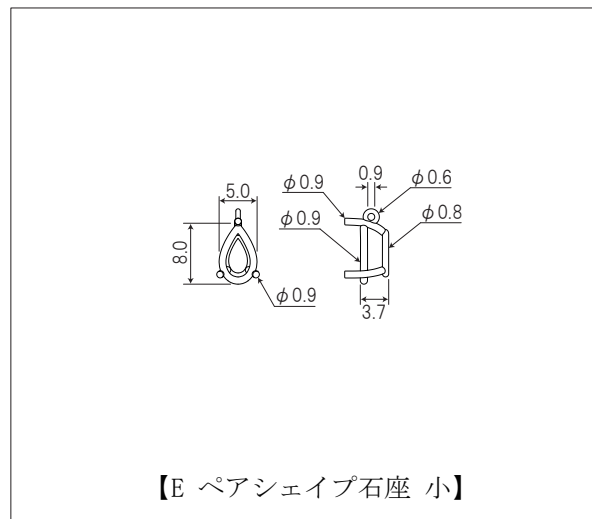
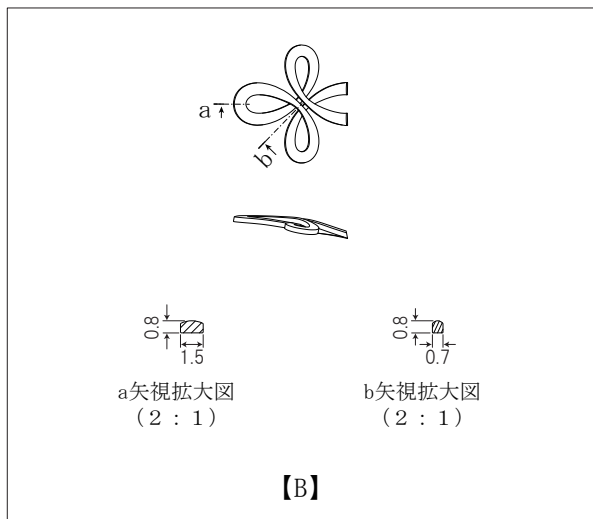

尺度	1 : 1	
名称	ペンダント (部品図)	
許容差	10mm未満	±0.05
	20mm未満	±0.3
	20mm以上	±0.5